

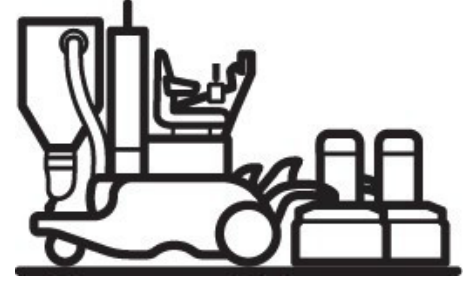

# Husqvarna®



## BMG 2200RC

Husqvarna, 2023-07-21

### **Operator's manual, EN**

Dear customer,

Thank you for choosing a Husqvarna quality product. We hope that you will genuinely enjoy it.

Please note that the enclosed manual contains BMG 2200RC references.

The Husqvarna Group is vouching for the quality of this product.

If you have any questions, please do not hesitate to contact our local sales or service point, or visit [www.husqvarnacp.com](http://www.husqvarnacp.com).

Husqvarna AB

SE-561 82 Huskvarna, Sweden

Inspection comments

Inspection before initial operation on:	_____
By:	_____
Date of initial operation:	_____
Serial number & Year of manufacture:	_____

Recurring inspections / maintenance log

Date / Hour counter	Findings	Repairs / Cleaning	Test on	By*

\*Competent person

# Table of contents

1. Introduction .....	5
1.1 Product liability.....	5
2. Machine description .....	5
3. Safety.....	7
3.1 General Safety Rules .....	7
3.2 Work area safety.....	7
3.3 Electrical safety .....	8
3.4 Grounded product instructions.....	9
3.5 Extension cables.....	9
3.6 Personal safety.....	9
3.7 Fire extinguisher.....	9
3.8 Machine safety general .....	9
3.9 Noise safety.....	10
3.10 Vibration safety .....	10
3.11 Maintenance safety .....	10
3.12 Safety for dust collector and pre-separator .....	11
3.13 Grinding safety.....	12
3.14 Transport safety.....	12
3.15 Symbols on the product .....	14
4. Initial operations.....	15
4.1 Electrical safety .....	15
4.2 Machine safety .....	15
4.3 The work area.....	15
4.4 To replace the wings / discs / pads.....	16
4.5 Before start-up.....	17
4.6 Seat and seatbelt.....	18
5. Operation .....	19
5.1 Touchscreen .....	20
5.2 Operation mode.....	22
5.3 Battery drive transport to work area .....	23
5.3.1 Power supply cable transport to work area.....	23
5.4 To prepare the pre-separator and dust collector.....	23
5.5 Start grinding .....	24
5.6 Stop grinding .....	24
5.7 Restart after a power-loss or EM-stop .....	25
5.8 To operate the grinding machine.....	25
5.8.1 Tracking .....	25
5.8.2 Grinding with 1, 2, or 3 heads.....	26
5.8.3 Grinding head pressure.....	26

5.8.4	Dust collector speed .....	26
5.8.5	Direction of the grind heads.....	26
5.8.6	Swivelling mode .....	27
5.9	Wet grinding (option) .....	27
5.10	Pre-separator and dust collector .....	28
5.12	Pulse cleaning system.....	30
5.13	Battery monitoring.....	30
5.14	Remote control operation .....	32
6.	Maintenance.....	33
6.1	Buffers .....	35
6.2	Main air tank.....	36
6.3	Compressor .....	37
6.4	Pulse system .....	38
6.5	Water separator .....	39
6.6	Filters maintenance.....	41
6.7	Filter replacement.....	42
6.8	Blower motor .....	43
6.9	Drive system .....	44
6.10	Maintenance of the battery charger Green 6 48/50 .....	46
6.11	Battery maintenance .....	48
6.12	To replace the batteries.....	48
6.13	Remote control maintenance.....	50
6.14	Maintenance screen.....	51
6.15	Input / Output screen.....	52
6.16	Remote Input / Output screen.....	52
7.	Troubleshooting .....	53
8.	Technical data.....	55

## 1. Introduction

**Warning:** Processing of concrete and stone by methods such as cutting, grinding or drilling, especially during dry operation, generates dust that comes from the material being processed, which frequently contains silica. Silica is a basic component of sand, quartz, brick clay, granite and numerous other minerals and rocks. Exposure to excessive amount of such dust can cause: Respiratory disease (affecting your ability to breathe), including chronic bronchitis, silicosis and pulmonary fibrosis from exposure to silica. These diseases may be fatal; Skin irritation and rash. Cancer according to NTP\* and IARC\* \*/ National Toxicology Program, International Agency for Research on Cancer. Take precautionary steps: Avoid inhalation of and skin contact with dust, mist and fumes. Wear and ensure that all bystanders wear appropriate respiratory protection such as dust masks designed to filter out microscopic particles. (See OSHA 29 CFR Part 1926.1153). To minimize dust emissions, use water to bind the dust, when feasible. If dry operation is necessary, use an appropriate dust extractor.

Before use, operators must be provided with information, instruction and training for the use of the machine and the substances for which it is to be used, including the safe method of removal and disposal of the material collected. All persons who are working with or maintaining this machine must read the manual carefully and understand it fully. In case you sell the unit, hand this manual over to the next owner.

Keep this manual always with the machine, to enable it to be referred to at any time.

Any other work not covered by this operating manual must not be carried out. Always use common sense when working with machines.

This machine is designed for industrial use by professionals. Only authorized and trained personnel may operate this machine. This machine is not intended for use by persons (including children) with reduced physical, sensory or mental capabilities, or lack of experience and knowledge. Husqvarna offers a course on the use of the machine in order to make the operating and maintenance personnel familiar with all elements of the machine.

Note: Make sure that you load the batteries weekly to keep them in good working condition.

### **1.1 Product liability**

As referred to in the product liability laws, we are not liable for damages that our product causes if:

- the product is incorrectly repaired.
- the product is repaired with parts that are not from the manufacturer or not approved by the manufacturer.
- the product has an accessory that is not from the manufacturer or not approved by the manufacturer.
- the product is not repaired at an approved service center or by an approved authority.

## **2. Machine description**

The BMG 2200RC ride-on three-head grinder is an electrical driven planetary grinding machine. The machine is designed for levelling and polishing of indoor concrete / stone floors. The 3 independently controllable grinding heads are fitted with 3 rotating discs per grinding head. The 9 planetary rotating discs have a diameter of Ø 240 mm. The rotating discs can be fitted with a wide range of different tools, ensuring a perfect finish for any job. The machine is suitable for dry and wet applications. The BMG 2200RC can be used on almost any floor to plane, to make ready for coatings, or to remove coatings or glue residues. The specially designed Husqvarna dust collection system ensures low-dust operation of the machine and clean air at the workspace.

## BMG 2200RC

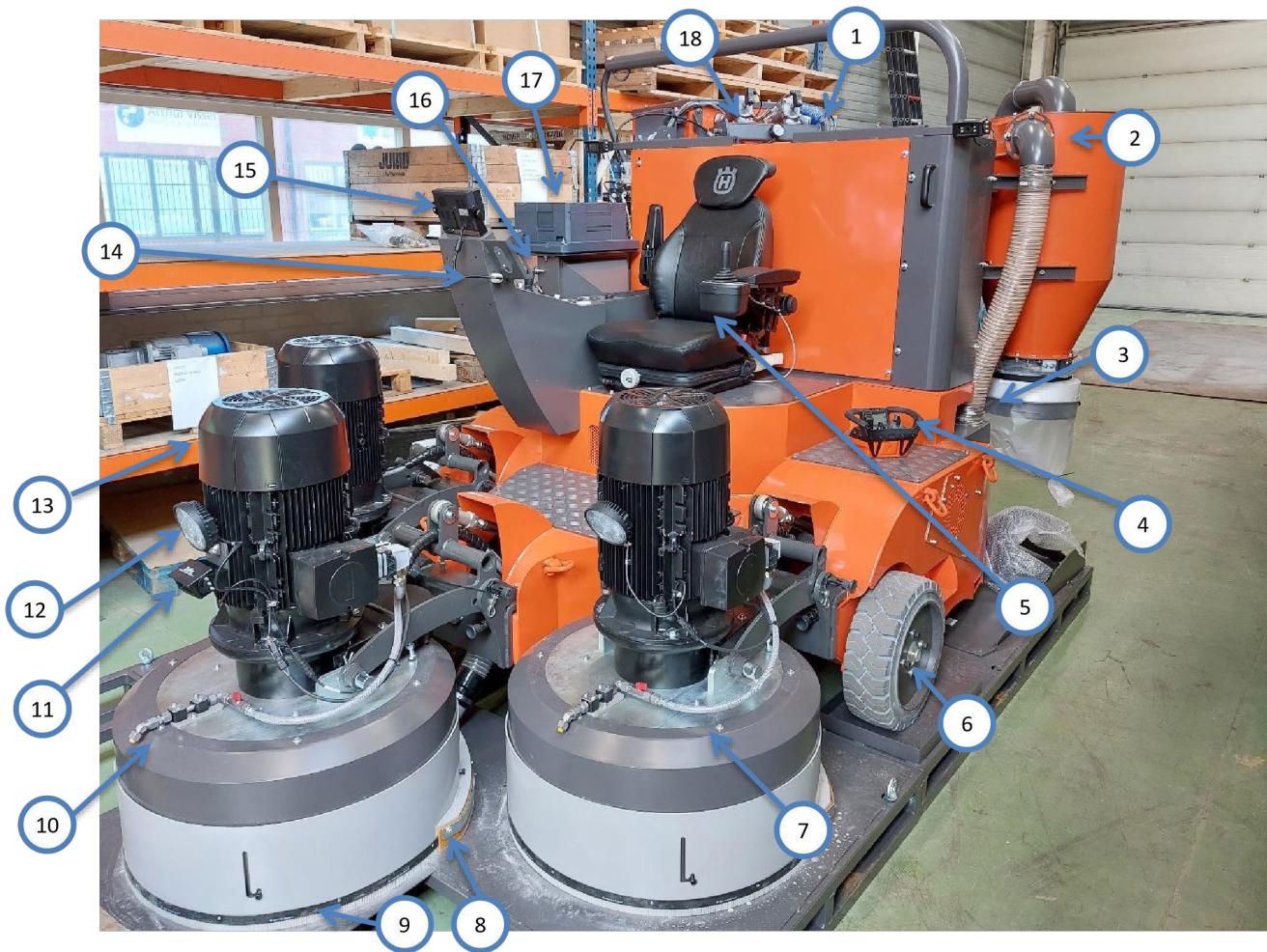

1	Dust collector	10	Water spray nozzle (optional)
2	Pre-separator	11	Front camera (optional)
3	Longopack bagging system	12	Head light
4	Remote control system (optional)	13	15 kW grinding motor
5	Ergonomic seat with joystick in armrest	14	Control panel
6	Drive wheels	15	Display of camera system (optional)
7	Grinding head	16	HEPA 14 filter
8	Rubber rear seal	17	T-loc case for tools
9	Floating shroud with brush sealing	18	Pulse system for automatic filter cleaning

## 3. Safety

### 3.1 General Safety Rules



**Warning:** Read all safety warnings and all instructions. Failure to follow the warnings and instructions can result in electric shock, fire, explosions and / or serious injuries or death to the operator or others.

**Warning:** Use approved respiratory protection when you operate the product.

**Warning:** No unauthorized person may operate this product.

**Warning:** Dump pre-separator in needed interval.

- Save all warnings and instructions.
- Comply with all applicable laws and regulations.
- The operator and the employer of the operator must know and prevent the risks during operation of the product.
- Use the handle and the footstep during entry and exit of the product.
- Do not go away from the product while the motor is on.
- Do not let a person operate the product unless they read and understand the contents of the operator's manual.
- Only authorized and trained personnel is allowed to operate this machine. This machine is not intended for use by persons (including children) with reduced physical, sensory or mental capabilities, or lack of experience and knowledge.
- It is the responsibility of the operator to analyse the work surface. The operator should make a risk assessment on the basis of the information obtained about the surface to be treated and take proper precautions for the work to be performed.
- Do not use the product in fog, rain, strong winds, cold weather, risk of lightning or other bad weather conditions. To use the product in bad weather or in wet locations can have a negative effect on your alertness. Bad weather can cause dangerous work conditions.
- Look out for persons, objects and situations that can prevent safe operation of the product.
- Do not use the product in areas where fire or explosions can occur. The product creates sparks and flammable material can create ignition with the dust or fumes.
- During operation, keep bystanders away from the area shown in the illustration below. The operator must be very careful in this area during operation.

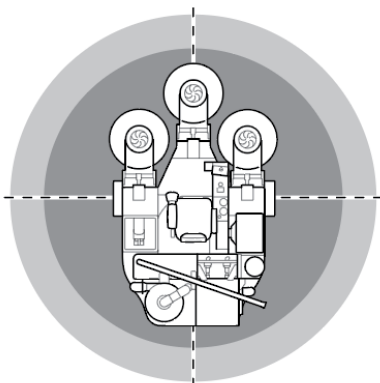

- Make sure that only approved persons are in the work area.
- Keep the work area clean and fully illuminated. Cluttered or dark areas invite accidents.
- Remove objects such as screws, bolts, wires and stones from the work area before you use the product.
- Make sure that there are no cables or hoses in the operation direction of the product.
- Make sure that uneven surfaces, such as welded seams or floor joints, do not stop the product.
- Make sure that there is sufficient airflow in the work area.
- In case of any inappropriate usage, improper operation or repair, the producer shall be exempt from liability.
- Maintenance work that goes beyond the scope described in this manual must only be performed by qualified Husqvarna technicians.
- Do not operate the product unless you receive training before use. Make sure that all operators receive training.
- The operator is responsible for accidents that occur to other persons or their property.
- Do not use the product if you are tired, ill, or under the influence of alcohol, drugs or medicine.
- Always be careful and use your common sense.
- This product produces an electromagnetic field during operation. This field can under some circumstances interfere with active or passive medical implants. To decrease the risk of serious injury or death, we recommend persons with medical implants to speak to their physician and the medical implant manufacturer before operating this product.
- Keep the product clean. Make sure that you can clearly read signs and decals.
- Do not use the product if it is damaged or does not operate correctly.
- Do not do modifications to this product.
- Do not operate the product if it is possible that other persons have done modifications to the product.
- Make sure to lock the wheels with the wheel lock when the product is parked.



### 3.2 Work area safety

**Warning:** There is always a risk of shocks from electrical products. Do not use the product in bad weather conditions. Do not touch lightning conductors and metal objects. Always use the product as given in this operator's manual to prevent injury.

- Do not use the machine in rain, damp or wet locations.
- Seal building to limit dust exposure.
- Set markings on your work area.
- Avoid dangerous environments. Do not work in the presence of explosive atmospheres, in the presence of flammable liquids, gases or dust. Remove materials or debris that can be ignited by sparks.
- The product creates sparks and flammable material can create ignition with the dust or fumes.
- Make sure that the working surface is clean. Remove all stones, screws etc. to prevent serious damage if they get inside the machine.
- Make sure that there is enough ambient light on the work area. Cluttered or dark areas can cause accidents.
- Do not use the machine on wood.
- Only load and unload the machine on a levelled and horizontal surface. Steep inclines can cause a dangerous situation when you lose control over the machine!
- It is necessary to provide for an adequate air change rate L in the room if the exhaust air is returned to the room. Comply with the national regulations.
- Keep children and bystanders away while operating the machine. They cannot foresee the potential dangers of the machine. Distractions can cause you to lose control of the machine.
- Persons who are not operating the machine must not be permitted to stay in the surrounding area of at least 15 meter from the machine.
- Never use the machine when the surface is not clear and if there is a risk of stumbling or tripping.
- Make sure that there are no cables or hoses in the driving direction of the machine.  
Make sure that there no objects standing or situated on the surface.  
Make sure the machine can travel over all inequalities on the surface. Small inequalities for example weld seams or floor joints are no barriers for the machine.
- Never stay in the rain with the machine.
- Do a check if there are any obstacles that can snag the cables when the machine moves.
- Remove reinforcing steel or other objects protruding from the surface in order to prevent damage to the machine.
- Make sure that the surface does not contain dangerous materials, such as:
  - combustible or explosive dusts or substances. -
  - carcinogenic or pathogenic substances.
- Secure the work area around the machine in public areas. Keep an adequate safety distance from the machine. Use a red and white safety chain and danger sign to enclose the work area.
- If the proper execution of the work requires the presence of workers in the work zone, it is mandatory to take effective measures to prevent them from serious injury.
- It is forbidden to use/drive the machine on public roads, pavements, etc. unless they are closed for the general public and other traffic.
- Only work on locations which are adequately ventilated.
- Do not use the product in areas where fire or explosions can occur. The product creates sparks and flammable material can create ignition with the dust or fumes.
- Make sure that only approved persons are in the work area.
- Keep the work area sufficiently illuminated.
- Make sure that there is enough ambient light on the work area. Cluttered or dark areas invite accidents.
- Remove objects such as screws, bolts, wires and stones from the work area before you use the product.
- Make sure that there are no cables or hoses in the operation direction of the product.
- Make sure that uneven surfaces, such as welded seams or floor joints, do not stop the product.
- Make sure that there is sufficient airflow in the work area.

### 3.3 Electrical safety

**Warning:** Always use a power supply with RCD (residual-current device). An RCD decreases the risk of electrical shock.

- Use only extension cables for extending the main cable that have size and marks in accordance with the overall power consumption of the machine. Do not use damaged extension cables.
- Make sure that the phases and the ground wire of the extension cable(s) are connected in the same order as the supply cable of the machine and the power supply.
- Electrical cables must be rolled entirely off of the reels.
- Any damage to the electric cables and/or electrical components is not permitted.
- If a cable or plug is damaged, it must be replaced immediately. Only use original Husqvarna parts.
- The voltage on the identification plate must comply with the power supply.
- Use an electrical power supply connection with ground connection and ground leakage circuit breaker.
- The circuit breaker of the power supply must have a "D" characteristic. Circuit breakers with "C" or "B" characteristic can cause problems when the motor starts.
- Keep the machine original. The machine is always equipped with a ground connection, do not change this and always use ground cables with a ground plug.
- Examine and test the electrical components regularly. The electrical components have to comply with the requirements set out in the harmonised norm EN60204-1.
- Always speak to a skilled electrician or your distributor when you have questions about the safety of the electrical components.
- Work on an electrical equipment or operating materials must be done only by a skilled electrician or by trained persons with the guidance and supervision of a skilled electrician as well as in accordance with the electrical engineering regulations.
- Always use tools that are insulated against high voltages.
- Do not abuse the cables. Never use the cables for carrying, pulling or unplugging the machine. Keep cables away from heat, oil, sharp edges or moving parts. Damaged or entangled cables increase the risk of electric shock and can cause serious injury and death.
- Be careful with water on the treated surface. Electrical cables must not come into contact with water.
- The main power switch on the machine must be in the "Off" position before you connect machine to the power supply.
- If the machine has a long standstill, pull out the main plug and cover it with plastic foil.
- If the machine uses power from a generator, the generator must be operated in accordance with the current legal regulations and directives in force (this applies to the protective ground conductor in particular). In order to make sure that all safety devices work properly and to eliminate possible damage to electrical components.

### 3.4 Grounded product instructions

**Warning:** Incorrect connection can result in electrical shock. Speak to an approved electrician if you are not sure if your mains outlet is correctly grounded.

- Do not do modifications to the power plug from its factory specification. If the power plug or power cord is damaged or must be replaced, speak to your Husqvarna service agent. Obey local regulations and laws.
- If you do not fully understand the instructions about the grounded product, speak to an approved electrician.
- Use only grounded extension cables with grounding plugs and grounding outlet that accepts the product power plug.
- The product has a grounded power cord and power plug. Always connect the product to a grounded mains outlet. This decreases the risk of electrical shock.
- Do not use electrical adapters with the product.

### **3.5 Extension cables**

- Use only approved extension cables with sufficient length.
- The rated value on the extension cable must be the same or higher than given on the rating plate of the product.
- Use grounded extension cables.
- Keep the connection to the extension cable dry and off the ground.
- Keep the extension cable away from heat, oil, sharp edges or moving parts. A damaged cable increases the risk of electrical shock.
- Make sure that the extension cable is in good condition and not damaged.
- Do not use the extension cable while it is wound up. This can cause the extension cable to become too hot.
- Make sure that the extension cable is behind you and the product when you use the product. This prevents damage to the extension cable.

### **3.6 Personal safety**

- Make sure that the operator and all bystanders wear appropriate respiratory protection such as dust masks designed to filter out microscopic particles, at least FFP3. (See OSHA 29 CFR Part 1926.1153).
- Always use approved hearing protection while you operate the product. Noise for a long period can cause noise-induced hearing loss.
- Always use eye protection while operating the product.
- Use protective gloves during when handling the product.
- Use safety shoes during operation.
- Make sure that clothing, long hair and jewelry do not get caught in moving parts.
- Do not use loose, heavy and not applicable clothing.
- Stay alert, watch what you are doing and use common sense when operating the machine.
- Make sure that the machine is stopped and all moving parts are complete standstill before any inspections, adjustments and/or maintenance work is started.
- All persons in the proximity of the machine, must wear hearing protection, safety shoes and safety glasses.
- Do not use the product if you are tired, ill, or under the influence of alcohol, drugs or medicine.
- Always seek professional medical attention immediately in case of injury.
- Limit operator's exposure under the sun.

### **3.7 Fire extinguisher**

- Keep a fire extinguisher near during operation.
- Use a powder fire extinguisher or a carbon dioxide fire extinguisher.

### **3.8 Machine safety general**

- Safety functions and operating functions must work correctly, examine them regularly.
- Loose bolts and nuts are not permitted.
- Never operate machine without the guards and/or safety devices in place.
- Never change anything on the safety devices on the machine!
- Do not use the machine if it is damaged.
- Do not open or remove protective guards while driving gears are running.  
Always wear gloves and only touch the handle grips. The temperature of certain machine parts can be above 37°C. The machine can heat up during work, without a risk of getting burned.

- The machine, especially the handle grips must be free of fats/oils and have to be dry.
- If the length of the brushes is (due to wear) less than 5 mm or they are extremely deformed, the brushes have to be replaced. Refer to the Service Manual for the order numbers.
- All repair work has to be done by qualified Husqvarna personnel, this guarantees a safe and reliable machine.
- Always use original Husqvarna spare parts, grinding disks, grinding wings and polishing pads. This ensures the best performance. Only original Husqvarna parts meet the factory specifications and quality. Otherwise Husqvarna cannot guarantee the safety of the machine. The part numbers are in the Service Manual.
- If safety-critical changes occur to the machine or its working method, stop the machine immediately! The cause of the fault must be established, and rectified.
- In the event of operational malfunctions, stop and secure the machine immediately!
- Before you start the engine, always make a pre-operation inspection, to prevent an accident or equipment damage.
- Look for signs of damage and remove any excessive dirt or debris.

### **3.9 Noise safety**

- High noise levels and long-term exposure to noise can cause noise-induced hearing loss.
- To keep the noise level to a minimum, do maintenance on and operate the product as given in the operator's manual.
- Use approved hearing protection while you operate the product.
- Listen for warning signals and voices when you use hearing protection. Remove the hearing protection when the product is stopped, unless hearing protection is necessary for the noise level in the work area.

### **3.10 Vibration safety**

- During operation of the product, vibrations go from the product to the operator. Regular and frequent operation of the product can cause or increase the degree of injuries to the operator. Injuries can occur in fingers, hands, wrists, arms, shoulders, and/or nerves and blood supply or other body parts. The injuries can be debilitating and/or permanent, and can increase gradually during weeks, months or years. Possible injuries include damage to the blood circulation system, the nervous system, joints, and other body structures.
- Overexposure to vibration can cause circulatory damage or nerve damage to persons with decreased blood circulation. Get medical aid if you have symptoms of overexposure to vibration. These symptoms include numbness, loss of feeling, tingling, pricking, pain, loss of strength, changes in skin color or condition. These symptoms usually appear in the fingers, hands or wrists.
- Symptoms can increase in cold temperatures. Use warm clothing and keep your hands warm and dry when you operate the product in cold environments.
- Do maintenance on and operate the product as given in the operator's manual, to keep a correct vibration level.
- The product has a vibration damping system that decreases the vibrations from the handles to the operator. Let the product do the work.
- Keep your hands on the handle or handles only. Keep all other body parts away from the product.
- Stop the product immediately if strong vibrations suddenly occurs. Do not continue the operation before the cause of the increased vibrations is removed.

### **3.11 Maintenance safety**

**CAUTION:** Do not point the high-pressure washer directly at seals or connection points.

- Pull out the main plug and place it in sight, before start the inspections and repair on the machine. Press the emergency shutdown button.
- Disconnect the negative battery terminal before start the maintenance work or set the battery insulation switch to off.
- Wait for standstill of all drives before any inspections, adjustments and maintenance work is started.

- 
- Block the machine in a stable position before you do any maintenance work.
- Use the air pistol and drain valve to depressurize the air pressure tanks before you do a maintenance.
- Do a regular maintenance. Failures due to inadequate or incorrect maintenance can generate very high repair costs and long standstill periods of the machine.
- Operational safety and service life of the machine depends, among other things, on proper maintenance. Prevent premature wear to keep the machine as dust free as possible. Clean the machine regularly with a dust collector and non-aggressive materials, especially the upper drive. Never use a high pressure water cleaner to clean the machine.
- It is advisable to stock all spare parts or wear parts that cannot be supplied quickly. As a rule, production standstill periods are more expensive than the cost of the related spare part.
- Do not use any aggressive cleaning materials and use lint-free cleaning cloths.
- To allow the user to do the maintenance operations, the machine must be disassembled, cleaned and inspected as far as reasonably possible, without causing hazards for the maintenance staff or other people.
- The suitable precautions include decontamination before disassembling the machine, adequate filtered ventilation of the exhaust air from the room in which it is disassembled, cleaning of the maintenance area and suitable personal protection equipment.
- Clean the external parts of the dust collector. Use the vacuum machine if necessary. Make sure that machine is dust-free before you drive from the hazardous zone. All parts of the dust collector must be considered as contaminated when they are removed from the hazardous zone and appropriate actions must be taken to prevent dust from dispersing.
- When maintenance or repair procedures are done, all the contaminated elements that cannot be properly cleaned, must be replaced.
- These contaminated elements must be disposed of in sealed bags according to the applicable regulations and in accordance with the local laws governing the disposal of such material.
- This procedure must also be followed when the filters have to be disposed.
- If dust goes out from the filter, the filter cartridges are damaged or it is not fixed correctly inside the chamber. Stop the machine immediately and examine the filter units.
- Replace the filter if you see the leakage. You must also clean the compartment above the filters and silencer.
- The compartments that are not dust-tight must be opened with suitable tools and thoroughly cleaned.
- Do not weld, flame cut or perform grinding works on or near the dust collector. Danger of fire or explosion exists!
- Provide adequate ventilation when you work in a confined space.
- Secure the maintenance area if necessary.
- Use the maintenance power supply (16 Amp) if power is needed during maintenance operations.
- Do the maintenance activities only on the ground level.

### 3.12 Safety for dust collector and pre-separator

**WARNING:** Do not use the dust extractor if the dust extractor hose is damaged. The risk increases that you breathe in dust that is dangerous to your health. Use respiratory protection.

- Always use the integrated dust collector when working dry to make sure that there is a dust-free operation of the machine and clean air at the workspace. Also the airflow helps to cool the machine and prevents overheating.
- Use the dust collector only for dry cleaning.
- Use the dust collector only to remove the non-combustible and non-explosive dust or substances.
- The machine does not apply for carcinogenic, pathogenic or asbestos substances.
- Do not use the machine in the dangerous atmospheres for example flammable gasses or dusts.
- The machine is designed for usage in conditions according to classification M.
- Never use the machine for suction of the water or liquids.
- Acids, acetone or solvents can damage the machine.
- Never use the machine without the filters in place!
- Never use the machine without Longopack bags attached.
- Do a regular check of the contents of the pre-separator and dust collector. Always wear a dust mask of at least class FFP3 when you change the Longopack bags. Comply with the local waste treatment regulations considering the removed material.
- The dust hoses must be connected properly with a hose clamp and industrial tape.

- 
- The dust hoses must be undamaged and free of obstructions.
- Daily use the air pistol and drain valve to remove water from the air tanks.
- When you temporarily stop the work (1/2 hour – 1 hour), turn off the fan unit only. Pulse cleaning of the filter system will continue and will increase the life-time of the filter cartridges.
- During a longer standstill of the dust collector, first set the fan unit to off. Let the pulse cleaning cycle run for +/- 5 minutes. Set the compressor and main-switch to off. Remove water from the pressure tanks.
- Always close off the butterfly valves of the pre-separator and dust collector when running the pulse cleaning cycle. Failure to do so can result in blown out dust, which can be hazardous to the health.
- Do not set to off or remove the exhaust and ventilation devices when the machine is operated.
- If dust goes out from the filter, the filter cartridges are damaged or not fixed correctly inside the chamber. Stop the machine immediately and examine the filter units.  
Replace the filter if you see the leakage. You must also clean the compartment above the filters and silencer.  
The compartments that are not dust-tight must be opened with suitable tools and thoroughly cleaned.
- Operators should observe all safety regulations appropriate to the materials being handled.
- Never expose the filter cartridges to moisture!

### 3.13 Grinding safety

- The grinding heads contain rotating parts, which are protected with sliding covers. Always keep the grinding heads on the floor while the motor works.
- The flexible couplings/buffers can become worn out with use, because of this there can be higher vibrations than normal. Examine the flexible couplings/buffers for deformation and damage before every use.
- Do not let the machine rest on the diamond disc or coupling when it is not in use, it causes deformation to the flexible coupling.
- Make sure that the brush seals are in good condition, to prevent dust escaping.
- Make sure the diamond tools (wings/discs/pads) are not damaged or worn out.
- Always pull out the main plug, set both main switches to off and press the emergency stop button before you start the replacement of the wings, disks or pads.
- For replacement of the disks/wings always put on a personal protective equipment.
- Use the vacuum cleaner to prevent excessive dust.
- Always put on a protective gloves when handling the grinding disks and wings. The grinding disks and wings heat up during grinding. There is a risk of getting burned.
- The machine has rotating parts. Never tilt the grinding heads backwards with a working motor.
- Be careful when use the machine and pull or let down the machine slowly, big shocks can damage the electrical parts.
- Make sure that the floating shrouds are in transport mode when you transport the machine.

### 3.14 Transport safety

**WARNING:** When operating the product on a ramp, always drive the product with the remote control.

**WARNING:** Maximum gradeability is 8%. Do not exceed gradeability 8% during grinding and transport.

**WARNING:** When operating the machine on ramp, always drive the machine with the remote control.

**WARNING:** Never walk behind or stand close on the edge of the ramp.

**WARNING:** Do not lift the machine on the tie-down points.

**WARNING:** For ramps with a steep slope, always use a winch. Do not walk or stay below the product. Do not stay in the product risk area.

**WARNING:** Be very careful when you move the product up and down ramps with the motor on. The product is heavy and there is a risk of injury if the product falls or moves too quickly.

•

•  
**WARNING:** Do not move the product on steep slopes. Look at the rating plate on the product for information about the maximum slope angle.

- Be aware of your surroundings and machine operating level. Do not side hill, do not run on steep incline (maximum incline 8%). The machine can fall or be damaged.
- Only load and unload the machine on a levelled and horizontal surface! Steep inclines can cause a dangerous situation when you lose control over the machine!
- Remove the dust from the pre-separator and dust collector before the machine is transported.
- The outside of the machine should be decontaminated by vacuum cleaning methods and wiped clean or treated with sealant before being taken out of a hazardous area. All the machine parts shall be regarded as contaminated when removed from the hazardous area and appropriate action taken to prevent dust dispersal, take precautions to prevent dust from escaping.
- The weight of the grinding machine is about 3035 kg. Use a flatbed trailer to transport the machine.
- Make sure that you obey all safety instruction when transport the machine.
- The product has tie-down loops that are used with tie-downstraps to attach the product to the transportation vehicle.
- Chock wheels for transport and keep control handles in neutral position.
- Don't leave the machine unsecured in a work area.
- Park the machine always on a flat horizontal and levelled surface.
- Make sure that the floating shroud is in transport mode when you transport the machine.
- Make sure that the electrical cables are disconnected.
- Store the cleaned and dry machine in a humid free room. Protect the electrical motor from moisture, heat dust and shocks.
- Never use the machine for lifting persons or items.
- Always drive forwards when driving up to a ramp or grade, and backwards when driving off the ramp.
- Make sure that the machine is not near the edge of the ramp.
- To lift the product use the BMG-2200 metal palled. To lift the palled you have to use a forklift.
- Remove the grind heads when you lift the product from behind in the forklift pockets.
- Only trained professionals shall lift the product with a forklift.

Never allow other persons besides the operator to be transported by the machine.

Transport mode

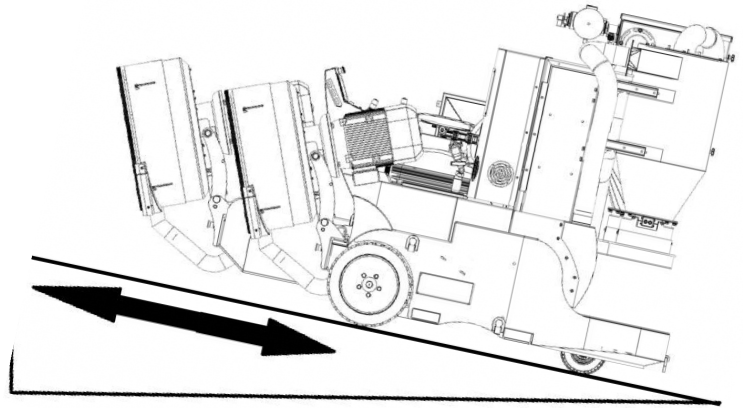

Maximum incline 8%



### 3.9 Symbols on the product



Electrical shock . Danger Hazardous voltage in motor even when solid state controller is OFF. Disconnect main power before servicing motor, controller or associated wiring.



Lifting point.



Tie-down points.



DANGER Rotating parts inside. Keep hands clear. Lock-out / shut down before servicing.



Keep all parts of your body away from hot surfaces.



Always wear approved hearing protection and protective goggles or a visor.

OPEN DRAIN VALVE TO REMOVE WATER FROM AIR TANK DAILY

Open drain valve to remove water from air tank daily.



Always use the safety belt.



Always use an approved breathing mask class FFP3 or higher.



Use approved hearing protection.



Use approved eye protection.



This product complies with applicable EC Directives.



This product conforms to the applicable UK regulations.



Use approved protective gloves.



Use approved protective boots.



Read the operator's manual carefully and make sure you understand the instructions



**No unauthorised person may operate this machine**

No unauthorised person may operate this machine.

### Type plate:

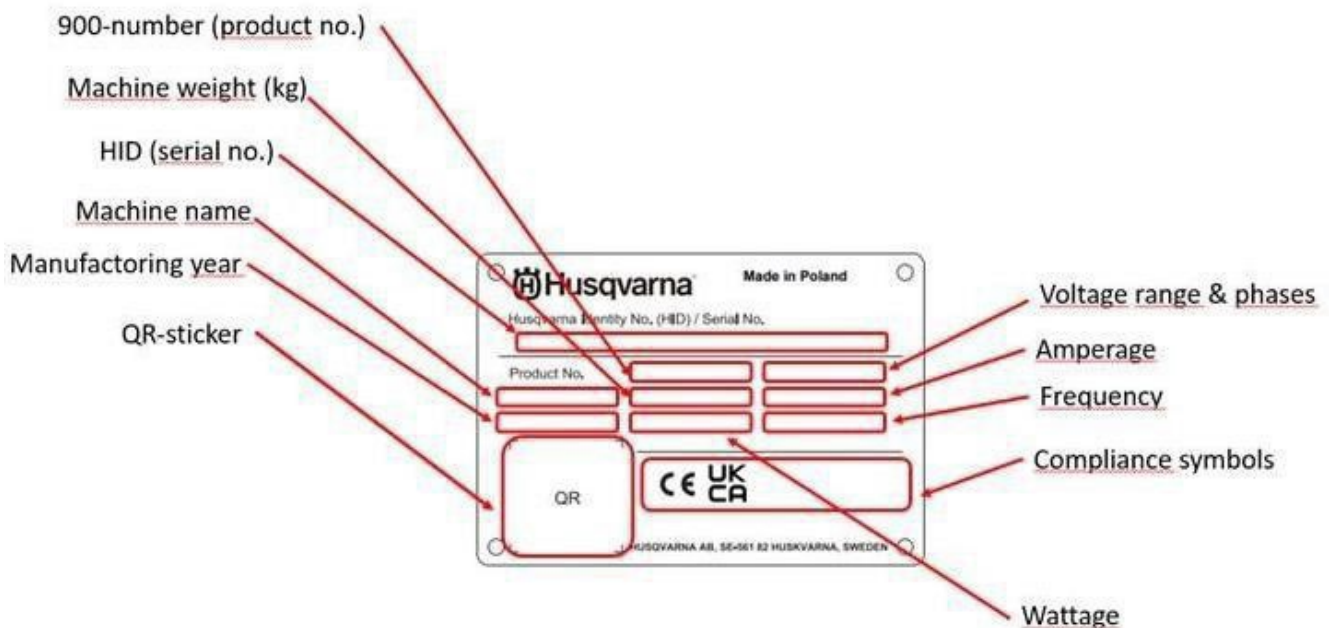

## 4. Initial operations

Examine the machine before the operation. Do a check of the below points to make sure that you can safely operate the machine.

### 4.1 Electrical safety

- Use only extension cables for extending the main cable that have size and marks in accordance with the overall power consumption of the machine.
- Electrical cables must be fully unwound of them reels.
- Make sure that the power cord and extension cable are in good condition and not damaged.
- Use an electrical power supply connection with a ground connection.
- The main switch of the machine is set to OFF position before you connect the power supply. Make sure that the power supply is in accordance with the machine specifications.
- Do a check of the electrical components, cables and connections for wear and/or damages.
- If the machine uses power from a generator, the generator must be operated in accordance with the current legal regulations and directives in force (This applies to the protective ground conductor in particular). In order to make sure that all safety devices operate correctly and to eliminate possible damage to electrical components.

### 4.2 Machine safety

- Make sure that machine operates correctly and you read and understand all safety instructions.
- Do a check of the diamond wings for damages and/or wear.
- The grinding head must touch the surface when you start the product.
- Do not start the product without the floating dust skirt installed. The dust skirt must seal fully between the product and the floor.
- Do a check of all screws and other fasteners for tightness. No loose bolts and/or nuts are permitted.
- Dust hose connections must be reliable. Use hose clamps and industrial tape.
- Make sure that the dust hoses are not damage and free of obstructions.
- Make sure that the pre-separator and dust collector are empty and the Longopack bags are connected properly.
- All water must be removed from the air tank and drain box. Excessive water can have a negative impact on the pulse power and shortens the life-time of the filter cartridges.
- The product can be operated by a remote control for long distances. Do not operate the product unless you have clear view of the product and its risk area. Cordon off the work area to prevent injury to bystanders.
- Inspect the dust hoses regularly, to control that they are not yammed.
- Do a check of the brush and rubber sealing of the floating shrouds.
- Do a check of the grinding heads on wear and defects. Remove foreign bodies and dust deposits.
- Do a check of the tools under the rotating discs.

### 4.3 The work area

- Be aware of surroundings for any unexpected presence of hazards.
- Do a check of the surface for loose parts (stones, screws, etc.). Clean the surface if necessary. Make sure the machine can travel over all inequalities on the surface. Small inequalities like weld seams or floor joints are not dangerous for the machine.
- Protect the work area around the machine. Keep the safety distance from the machine. Use a red and white safety chain and danger sign to enclose the work area.
- Remove reinforcing steel or other objects protruding from the surface to prevent damage to the machine.
- Make sure that the surface does not contain dangerous materials, such as:
  - combustible or explosive dusts or substances.
  - carcinogenic or pathogenic substances.
- Make sure that the machine moves around only if the power supply cables are disconnected.
- Always make sure that all rotating parts are completely standstill before move up the grinding heads and drive the machine.
- Make sure that nobodies feet get under the wheels. Put on appropriate safety shoes when you drive the machine to or from the work area.

#### 4.4 To replace the wings / discs / pads

**Warning:** Use approved respiratory protection, protective gloves and eye protection when you replace the diamond tools. The dust below the grinding head is dangerous to your health.

**Warning:** Stop the motor and disconnect the power plug from the power supply before tool change. Make sure that all drives stop and the product is cooled down.

**Warning:** Always keep a distance from the grinding head when tilting.

**Warning:** Use protective gloves, as diamond tools can become very hot.

**Warning:** Use the dust extractor when you replace the diamond tools. The dust extractor will decrease the dust that can cause health problems.

- Always wear a dust mask of at least class FFP3 and gloves.
- Use the vacuum cleaner in order to work as dust free as possible



Make sure that all moving parts of the machine are standstill before replace the wings.

Move the grinding heads to the UP position and safety them with the quick release pins. One pin on each side of each grind head.

Quick release pins for securing the grind head in the UP position.

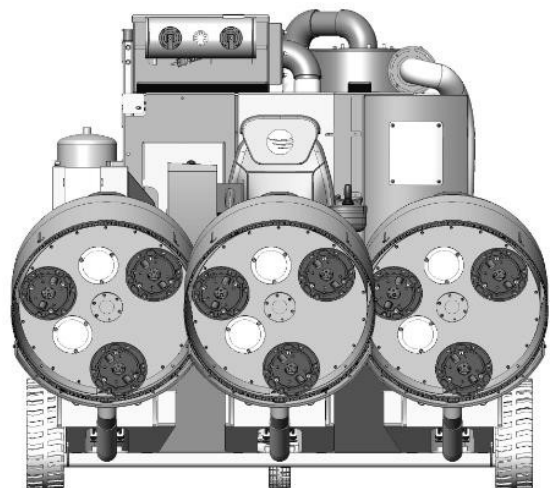
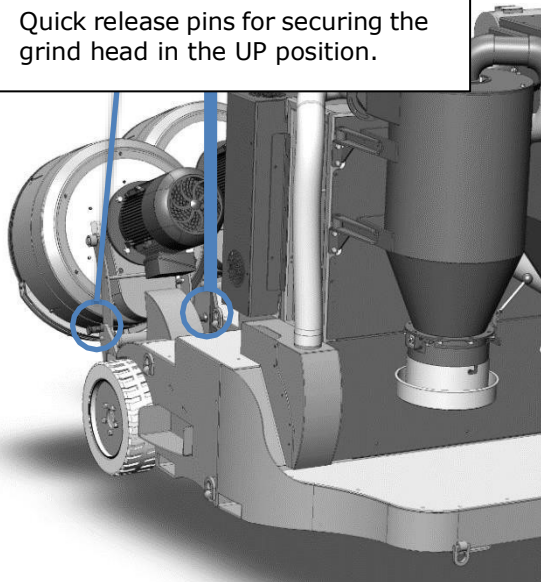

To remove the diamond wings

1. Refer to chapter 3. Safety and put on a personal protective equipment.
2. Make sure that all moving parts of the machine are completely standstill before replace the wings.
3. Secure the grinding heads in the UP position with the quick release pins. There is one on each side of each grind head.
4. Remove all the dust with a vacuum cleaner.
5. Remove the tools.

To install the diamond wings

1. Refer to chapter 3. Safety and put on a personal protective equipment.
2. Make sure all moving parts of the machine have come to a complete standstill before changing the wings.
3. Safety the grinding heads in the UP position with the quick release pins. There is one on each side of each grinding head.
4. Clean the Diamag plates with a vacuum cleaner to make sure that the diamond wings are attached correctly to the plate. Dirt between the plates and wings causes the rough grinding results.
5. Install the tools.

#### **4.5 Before start-up**

Before start the operation personnel must read and understand the safety regulations given in this manual.

- Put the grinding machine on to the surface to be processed.
- Fit the appropriate diamond grinding wings that are required for this particular process. Refer to chapter 4.4 of this manual.
- Connect the machine to the electricity supply point. Make sure that the electric supply point is safe and equipped with a ground connection and ground leakage circuit breaker. In case of doubt speak to the local safety officer.
- Do a check of the dust hoses for damages and obstructions. Make sure the Longopack bags of the dust collector and pre-separator are empty. Observe the local regulations regarding waste disposal.
- Before grinding, clean the surface. Make sure that there are no trash, stones, cloths, or oil on the surface.

Remove all objects from the surface that can damage the machine. Remove reinforcing steel or other objects protruding from the surface in order to prevent damage to the machine, the seals or diamond wings.

## 4.6 Seat and seatbelt

Adjust the seat as needed and sit up straight and well back in the seat.

**WARNING:** The seat belt needs to be used during grinding. The operator should always wear the seat belt no matter how short the product is being transported. The seat belt minimizes the risk of injury in the event of a crash or an emergency stop. In an accident, an unbelted operator can cause serious injury.

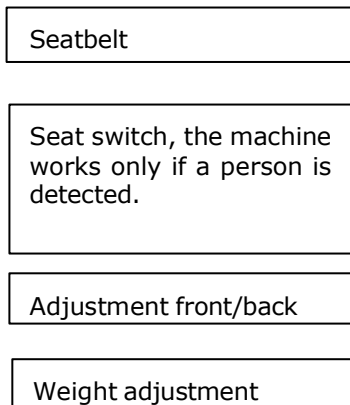
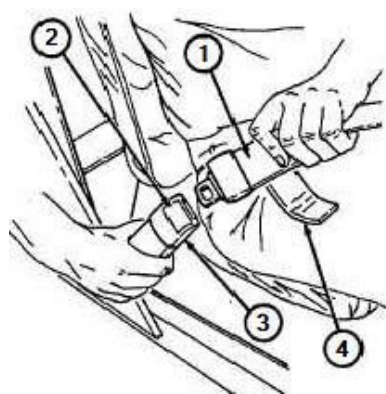

To fasten your seat belt, pull the webbing (1) out of the retractor and insert the metal tongue into the buckle (3). There will be an audible “click” when the tab locks into the buckle. Pull on the strap (4) to tighten the lap belt across your hips. The lap belt should be worn snugly and as low as possible over the hips, do not wear it over your belly.

To release the belt, press the buckle release button (2) and allow the belt to retract. If the belt does not retract smoothly, pull it out and check for kinks or twists. Then make sure it remains untwisted as it retracts.

Periodically check the seat belt to be sure it remains snug and in position. If there is a sudden stop or impact, the belt will lock into position. It will also lock (restrict) if you try to lean forward too quickly.

Important points about the seatbelt:

- Reduce the possibility of being thrown from the machine.
- Reduce the possibility of injuries to the body during an accident or collision.
- Hold the driver in a position which allows better control of the machine.
- The belt must always be flat against your body and not twisted in any way. Do not put any objects between you and the seat belt. Incorrect use of a seat belt can cause serious injury.
- Adjust seat belts as tightly as possible, consistent with comfort to properly secure the operator in the seat.
- Do not use any accessories on the seat belt or modify in any way the seat belt system.
- An accident or emergency stop, can make your seat belt system damaged. Examine the seat belt system after every accident.
- Never use a damaged seat belt system. A damaged seat belt can cause serious injury.
- Examine the seat belt systems regularly. Do a check if there are no visible damages. They must be handled with care.

- Keep the belts clean and dry. Belt retraction can be difficult if the belts are not clean. Clean the belts with a mild soap solution or lukewarm water. Never use bleach, dye, or abrasive cleaners. These chemicals make the belts weak.
- Never wear twisted seat belts. Excessive forces go from the belt to the operator in a collision and can cause serious injury.
- At least once each month, examine the seat belt for any cuts, tears, or other signs of wear (such as fraying along the edges). Make sure that the anchor, retractor and buckle are tight and operational.

1	Joystick (left-hand) for driving forward / reverse
2	Cruise control button
3	Grinding speed
4	Remote control ON / OFF
5	Lights ON / OFF
6	Start grinding
7	Compressor ON / OFF
8	Stop grinding
9	Joystick (right-hand) for left and right movement button on top for 360° turning
10	Dust collector ON / OFF
11	Drive speed adjustment (during cruise control)
12	Fingertip toggles for Grinding head 1, 2, 3 UP or DOWN
13	Freeflow ON / OFF
14	Ignition key
15	Horn
16	Switch for battery isolation
17	Amp. main power supply connector
18	Connection for external compressor
19	Main switch
20	EM-stop console

## 5. Operation

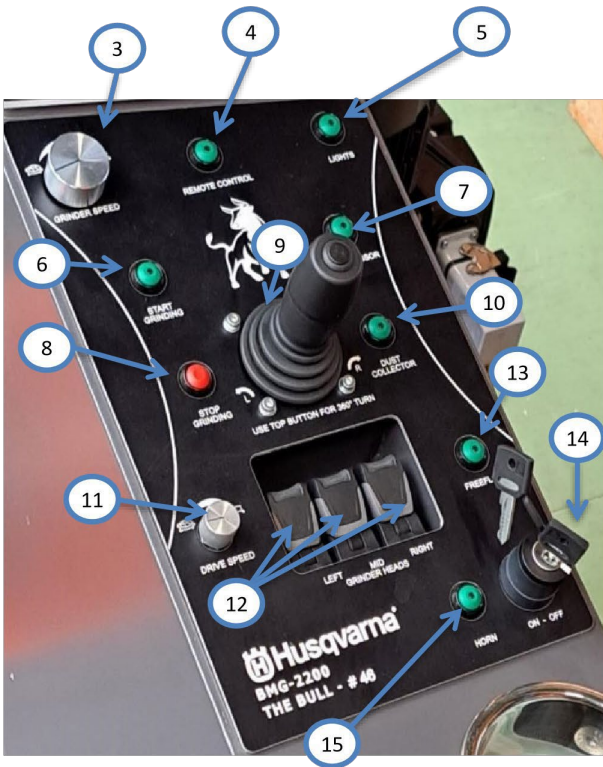
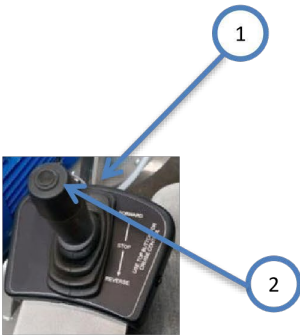

## 5.1 Touchscreen

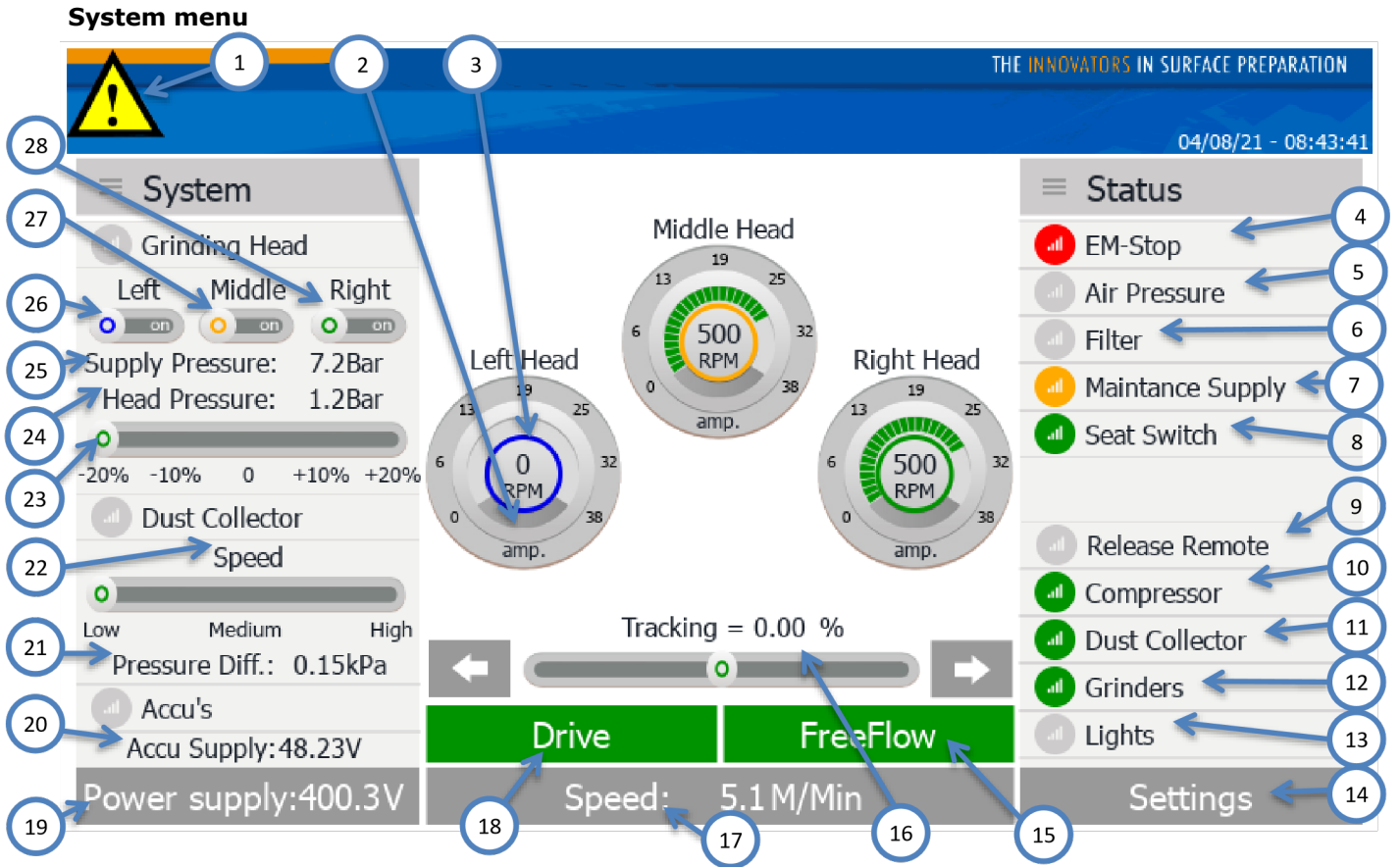

1	Error warning	18	Cruise control activated notification
2	Ampere grinding head LEFT (1)	19	Amount of Volts received from power supply 380Vac is warning, 355 Vac is alarm
3	RPM grinding head LEFT (1)	20	Amount of Volts received from Accu's 47 V will give a warning, 45V will give Pop-up alarm 43 V Stop pop-up, ps the machine. Load the batteries weekly
4	Emergency stop notification	21	Pressure difference of the filters in kPa (or) IN W.C.
5	Air pressure notification (Orange = Low pressure = $\leq 6$ bar) (Red = too little pressure = $\leq 5.5$ bar)	22	Suction power of the dust collector (L-M-H)
6	Filter notification (Orange = Filters almost clogged = $\geq 1.75$ kPa) (Red = Filters clogged = $\geq 1.9$ kPa)	23	Control for head pressure of the grinding heads onto the surface
7	Maintenance supply notification	24	Pressure of the grinding heads onto the surface in bar (or) PSI
8	Seat switch notification	25	The supply air pressure in bar (or) PSI
9	Release Remote notification	26	Grinding head LEFT Activate / Deactivate
10	Compressor ON/OFF notification	27	Grinding head MIDDLE Activate / Deactivate
11	Dust Collector ON/OFF notification	28	Grinding head RIGHT Activate / Deactivate For 26, 27 and 28:  Blue = Ready for use Green = Rotating at correct speed
12	Selected grinding motor(s) ON/OFF notification		
13	Lights ON/OFF notification		
14	Settings menu		



15	FreeFlow activated notification	Orange = Accelerating or decelerating Red = Error
16	Tracking control of the drive wheels in %	
17	Drive speed in meter/second (or) feet/minute	

**Error warning menu**

Select	Description	Time	Value	State
<input type="checkbox"/>	Air Pressure Low Low	4-8-2021 08:42:53	1	Triggered Not Acked
<input type="checkbox"/>	Emergency Stop Active	4-8-2021 08:42:53	1	Triggered Not Acked
<input type="checkbox"/>	Supply Voltage Low Low	4-8-2021 08:42:53	1	Triggered Not Acked
<input type="checkbox"/>	Air Pressure Low	4-8-2021 08:42:53	1	Triggered
<input type="checkbox"/>	Supply Voltage Low	4-8-2021 08:42:53	1	Triggered

Buttons: Check/Uncheck All, Acknowledge, Back

1	The check-box for error / warning	6	Acknowledged error / warning (yellow)
2	Description of error / warning	7	Back to main menu
3	Date and time of error / warning	8	Acknowledge selected errors / warnings
4	Value of error / warning	9	Check / Uncheck All errors / warnings
5	Current state of the error / warning		

**To remove errors / warnings**

To remove errors, do the steps as follow:

- Carefully read the warning (2), do a check of the time (3) and the current state of the warning (5).
- Select the warning (1) and press "AKNOWLEDGE" (8).
- The color of warning changes from red to yellow (5), the state changes from "Triggered Not Acked" into "Triggered" (5).
- Click on "CHECK / UNCHECK ALL" (9) to select all warnings at once.
- Click on "AKNOWLEDGE" (8) to remove all warnings / errors.
- Click on "BACK" (7) to go back to the main menu.

## Settings menu

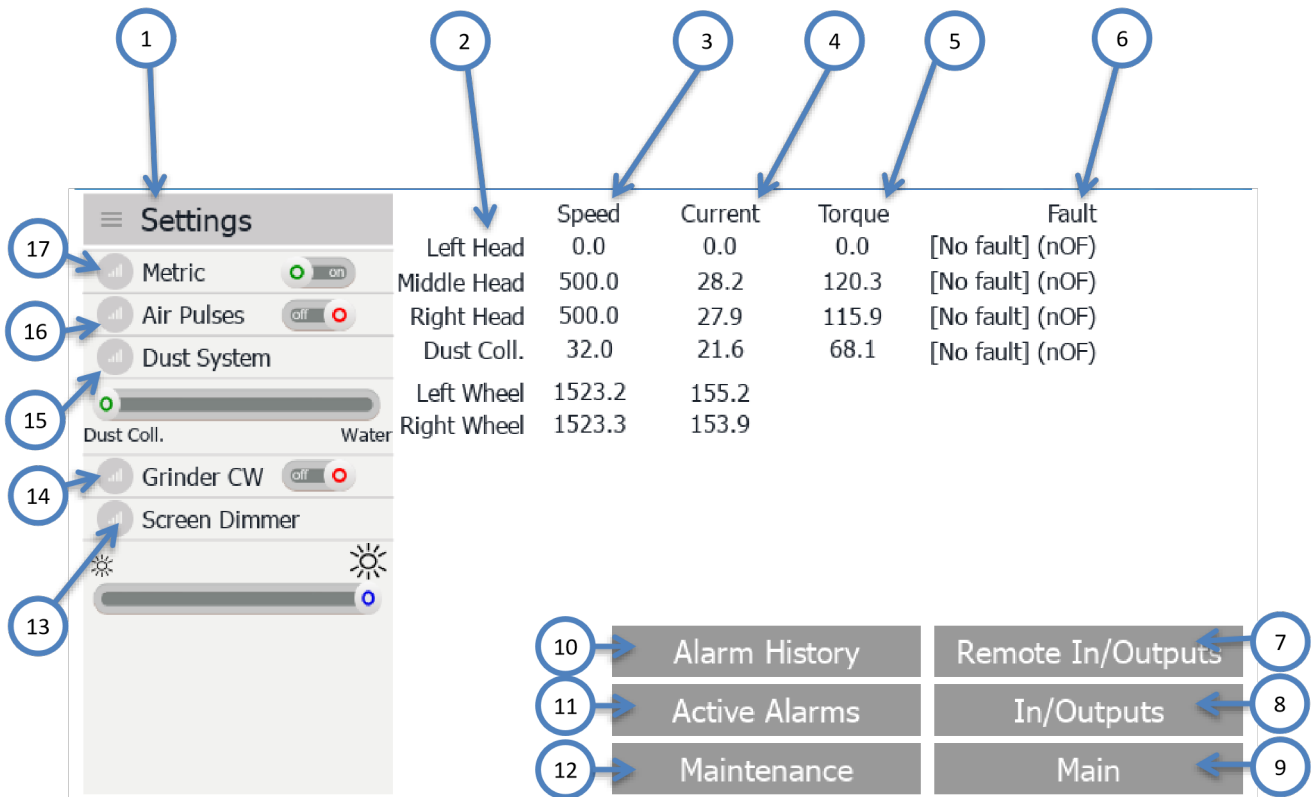

1	Settings menu	10	Alarm history menu
2	Description of machine item	11	Active alarms , Error warning menu
3	Turning speed	12	Maintenance menu
4	Current of machine	13	Screen dimmer, brightness of the touch screen
5	Torque	14	Grind heads turning counterclockwise ON/OFF (OFF is normal turning direction of grind heads = clockwise)
6	Fault	15	Selection for dry or wet grinding
7	Remote IN/Outputs menu	16	Air pulse ON/OFF (to activate pulse when DC is off)
8	IN/Outputs menu	17	Indications in Metric or Imperial
9	Back to main menu		

## 5.2 Operation modes

The BMG 2200RC features various operating modes.

### Battery drive operation

Note: Make sure that you load the batteries weekly to keep them in good condition. This enables you to drive the machine to and from the work area without the use of any cables.

In the operation mode you can only drive, other functions are shut down.

*The batteries are charged automatically when the machine is connected to the main power supply.*

The display shows the battery voltage (20, refer to fig. Touchscreen on page 20). When voltage reaches 47 V and warning is shown, stop the machine and load battery fully.

When the battery reaches 45 V an red pop-up is shown, you must stop the machine and load the battery. If you do not stop the machine, the damage of the battery can occur.

When the voltage reaches 43 V the machine stops.

The machine has a battery monitor at the rear.



### Power supply cable operation

This is the normal operation mode for the machine. All functions for normal operation are enabled. Make sure that the power supply cable has no damages when you operate the product.

*The connector is 5 p, 125 Amp. The machine requires 3x400V power supply.*

When the main power of the machine is ON, the battery works and the loader is loading the battery. Do a check of the battery voltage as described above.

The main power switch on the product must be in the "Off" position before you connect the product to the power supply.

### Maintenance operation 16 Amp

Connect the 16 Amp connector to the power supply for maintenance operation. The grinding heads do not work in this setting.

Only drive the machine to and from the work area with the grind heads in the UP position. Safety them with the quick release pins.

### 5.3 Battery drive transport to work area

Refer to fig. on page 19.

1. Turn the battery switch to ON (16).
2. Use the ignition key (14) to start the machine.
3. Do a check of the touch screen for errors and warnings.
4. Use joysticks (1) and (9) and push the sign to drive the machine to the work area.
5. When you stop the machine after work, turn the battery switch to OFF and connect the machine to the 400 Vac.



#### 5.3.1 Power supply cable transport to work area

Refer to fig. on page 19.

1. Turn the battery switch to ON (16).
2. Connect the plug of the machine to the power supply 3x400V , 5p 125 Amp
3. Set the main switch to ON (19).
4. Use the ignition key (14) to turn the machine on.
5. Do a check of the touch screen for errors and warnings.
6. Use joysticks (1) and (9) to drive the machine to the work area.



(17).

### 5.4 To prepare the pre-separator and dust collector

Refer to fig. on page 24.

1. Open the butterfly valves of the pre-separator and dust collector. Pull the levers towards you until they are in a horizontal position (1).
2. Turn the bag full of dust (2) on itself to obtain a section of coiled bags to be tightened with two clamps (3).
3. Place the two clamps at a distance of 50 mm / 2 in. between them, then with a pair of scissors cut between the two clamps.
4. Remove the bag full of dust (2) and pull out a new section of Longopack (4) about 35 cm / 13 in.

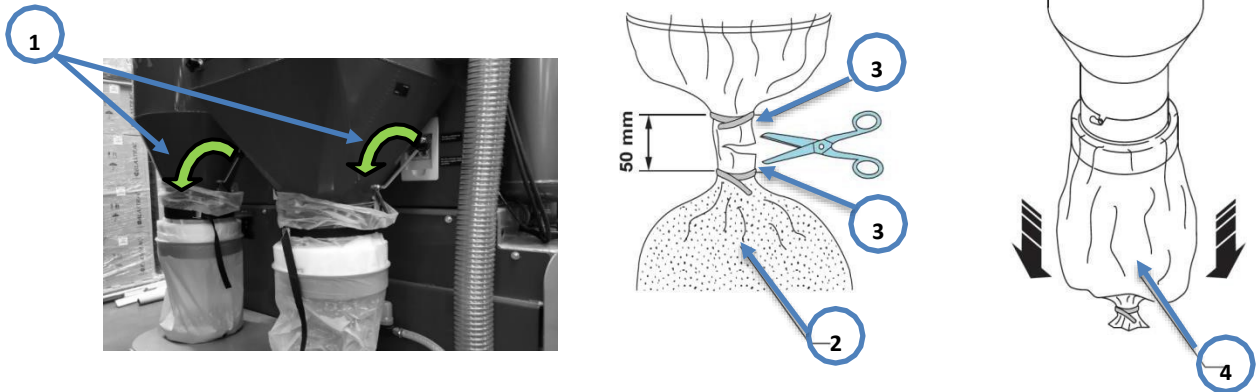

## 5.5 Start grinding

Refer to fig. in chapter Operation on page 19.

1. Sit down in the control seat and fasten the seatbelt.
  - *The seat is equipped with a sensor that will detect if a person is present in the control seat. The product will not start if the operator is not seated.*
2. Do a check if there are any faults in the error / warning menu.
3. Start the compressor (7).
  - *The compressor builds up pressure needed for operation.*
4. Loosen the quick release pins which hold the grind heads in the UP-position.
  - *It could be possible that the fingertip toggles (12) need to be operated if the quick release pins won't come loose.*
5. Start the dust collector (10).
  - *Make sure that the Longopack bags are empty and in correct position.*
6. Press "FREEFLOW" (13), or lower the grind heads with the fingertip toggles (12).
  - *The grind heads will lower to the surface. (Grind heads must be activated in the system menu, items 26, 27 and 28, refer to fig. on page 20).*
7. Make sure that the Head Pressure selection (24, refer to fig. on page 20) is set to -20 before you start.
8. Press "START GRINDING" (6).
  - *The grind heads turn.*
9. Use the joysticks (1) and (9) to start driving.
  - *Use the button (2) on top of the left-hand joystick (1) to activate the cruise control.*
  - *Use the "DRIVE SPEED" turning knob (11) to adjust the drive speed in cruise control mode.*
10. Observe the main screen to see the RPM's and Amps of the grind heads.
  - *Adjust the RPM's of the grind heads with the "GRINDER SPEED" turning knob (3).*

In case of emergency or operating trouble, for example vibrations or strong noises, set the machine to off immediately! Refer to chapter "Stop grinding" or push the red emergency button above the touch screen.

## 5.6 Stop grinding

Refer to fig. in chapter Operation on page 19.

1. Stop driving.
  - *Put the left-hand joystick (1) in the centre position to stop the machine.*
2. Stop grinding.
  - *Press the "STOP GRINDING" button (8) to stop grinding.*
3. Stop the freeflow.
  - *Press the "FREEFLOW" button (13) to stop the freeflow. The freeflow indication on the Touchscreen comes off.*
4. Move up the grind heads.
  - *Use the fingertip toggles (12) to move up the grind heads and secure the grind heads in the UP position with the quick release pins.*
5. Stop the dust collector.

- Push the "DUST COLLECTOR" button (10) to stop the dust collector. The little light in the button goes off.
6. Stop the compressor.
    - Push the "COMPRESSOR" button (7) to stop the dust collector. The little light in the button goes off.
  7. Use the ignition key (14) to set the machine to off and disconnect the power supply.

### 5.7 Restart after a power-loss or EM-stop

To restart the machine after a power-loss or EM-stop, do the steps as follow

1. Press the EM-stop on the console (20, refer to fig. on page 19).
2. Do a check if you can start safe operations.
3. Put the joysticks in the middle position.
4. Release EM-stop button on the console.
5. Do the steps from chapter 5.4 Start grinding.

### 5.8 To operate the grinding machine

This machine always has a grinding result because of the planetary system.

It is recommended to keep the machine in constant movement for an optimum grinding result.

For soft floors it is recommended to work with low head pressure, for hard floors and the first steps of polishing it is recommended to grind with low speed of the tools and more head pressure.

Speak to Husqvarna experts for the correct application of the different tools and their related working speeds.

Do a grinding on parallel tracks in such way that the electric cable does not become twisted. The next figure shows the recommended grind paths leading away from the power source.

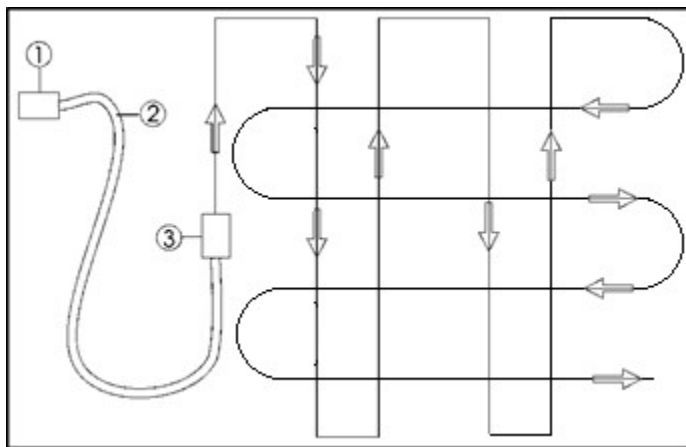

1	Power source
2	Electric cable
3	Grinding machine

The speed mode depends on the material of the surface and the desired profiling.

**WARNING:** Use protective gloves, eye protection and respiratory protection during change of dust bag.

Regularly examine the contents of the pre-separator and dust collector and do a manual dump of the pre-separator in needed intervals. Make sure to empty the dust bag before it becomes too heavy. Use Husqvarna longopack and cables ties. Comply with the local waste treatment regulations considering the removed material.

Make sure that the vehicles, for example forklift, trucks and other equipment do not move across the electric cables.

For soft floors it is recommended to work with hard bonded diamond tools, for hard floors it is recommended to grind with soft bonded diamond tools.

### 5.8.1 Tracking

One drive wheel can have more traction than the other drive wheel because of rough surfaces.

To make sure that the grinding lines are perfectly straight, use the tracking control (1).

The tracking control can also be useful when grinding close to the wall.

Use the arrow keys to adjust the driving deviation to the left or right.



### 5.8.2 Grinding with 1, 2, or 3 heads

The 3 grinding heads can be used independently. You can use 1, 2 or 3 grinding heads in every combination. Raise the grinding head(s) you do not use and secure in the UP position with the quick release pins.

Turn the particular grinding head(s) off (12, 13 and/or 14) in the SYSTEM MENU:

### 5.8.3 Grinding head pressure

Use the "HEAD PRESSURE" selection (10) to increase or decrease the pressure of the grind heads on the working surface.

-20%	There is less pressure on the surface.
-10%	
0	There is the normal pressure, equal to a BMG-780.
+10%	There is more pressure on the surface.
+20%	



### 5.8.4 Dust collector speed

The suction power of the dust collector can be adjusted to the particular type of surface / grinding tools / work speed etc. Select one of the options: "LOW" - "MEDIUM" - "HIGH" in the dust collector speed selection (8). The Pressure Difference of the filters (7) below the speed selection is indicated in kPa or in. water colom when metric is not selected.

### 5.8.5 Direction of the grind heads

The normal direction of turn the grinding heads is clockwise (CW) and the grinder CCW selection is OFF. It is possible to turn the grind heads counterclockwise (CCW). Go to the SETTINGS MENU and select ON in the "Grinder CCW" section (4).

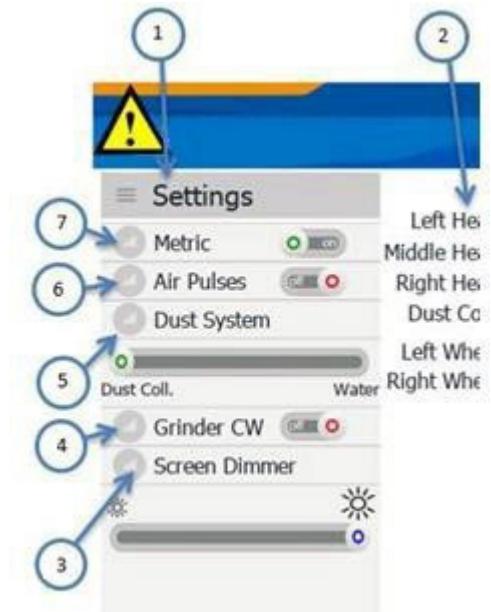

### 5.8.6 Swivelling mode

If the surface is very flat after several steps of grinding, the grind heads can be set to the less swivelling mode. The less swivelling mode could help to get a perfect finish for the polishing process.

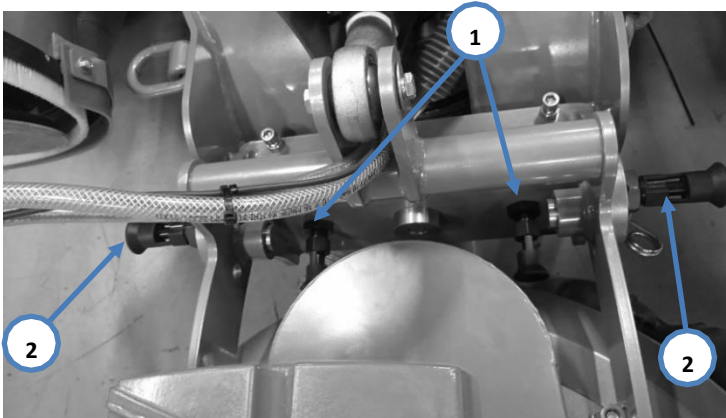

(1) Quick release pins for swivelling mode.

(2) Quick release pins that keep the grind heads in the UP position.

Loosen the 2 quick release pins (1) to swivel the heads. Use the Freeflow mode to have the best results.

### 5.9 Wet grinding (option)

The BMG 2200RC can also be used for wet grinding (option). The water from the water tanks goes through an easily accessible filter and then to the spray nozzles which are mounted to the front of every grinding head. The water tanks and every spray nozzle can be opened and closed separately. The water keeps the grinding tools cool and makes them more aggressive. The water spray prevents airborne dust which benefits the health and safety of the operator.

**Warning:** Never use the vacuum cleaner when grinding wet!

To install the water system, the pre-separator and dust collector must be replaced by 2 water tanks of 200 liter / 54 gallons each. (It is possible to replace only 1 water tank)

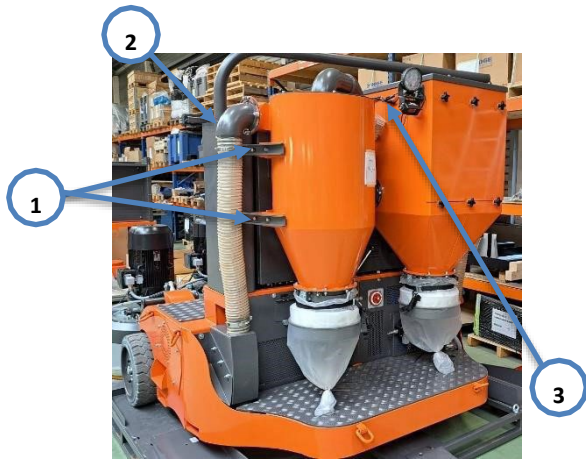

1. Loosen the 2 bolts (1) on top of the hinges of the pre-separator.
2. Loosen the hoseclamp and dust hose (2) of the pre-separator.
3. Disconnect the cables of the back-light and back-camera (3).
4. Loosen the hoseclamp and dust hose (3) between the pre-separator and dustcollector.
5. Loosen the hose clamp and dust hose (5) that go from the dustcollector to the machine frame.
6. Loosen the 3 bolts (4) on the top of the hinges of the dustcollector.
7. Loosen the air hose (5) from the pulse tank.
8. Loosen the small blue hoses from the 2 small filters (6).
9. Loosen the actuators (7) from the pulse valves.
10. Disconnect the electrical cable of the Dwyer Magnesense (11).
11. Loosen pin to disconnect the pre-separator (8).
12. Clean the system with the air pistol (9).
13. Observe the air pressure gauge (10).
14. Use a crane or other lifting device to lift the pre-separator off of the hinges and put it on its side to prevent damages. Do not set the pre-separator down on the Longopack.
15. Place the water tanks on the hinges.
16. Connect the hose from the water tank to the water-filter (12), safe the hose with the hose clamp.

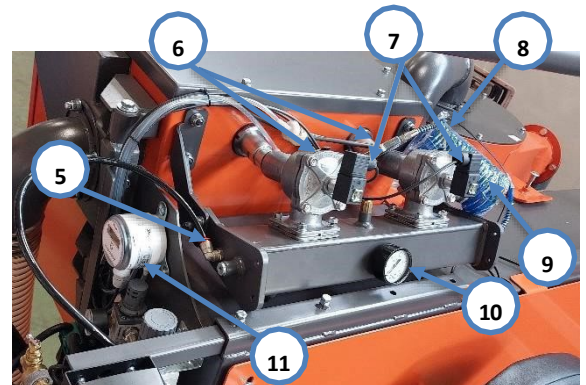

17. Go to the SETTINGS MENU (14, refer to fig. on page 20) and select "Water" (15, refer to fig. on page 20) in the "Dust System" selection area.
18. When "Water" is selected, the dust collector cannot be operated and vice versa.
19. Open all valves and use the "DUSTCOLLECTOR" button (10, refer to fig. on page 19) to activate the water spray nozzles in the MAIN MENU.
20. Fill the water tanks with a clean water. Dirty water can clog the system.
21. Remove the screws to open the caps, on top of the water tanks, to fill them. Do not forget to close the caps after you fill them. Splash of the water can damage the electrical system.
22. Make sure that the water supply is stopped before you connect or disconnect it to the machine. Be careful, the work floor can get slippery when grinding wet. Keep all electrical cables and connections away from water.
23. Clean the brush-sealing directly after wet grinding. It is not easy to remove the dry and hard dustwater mixture from the brush-sealing.

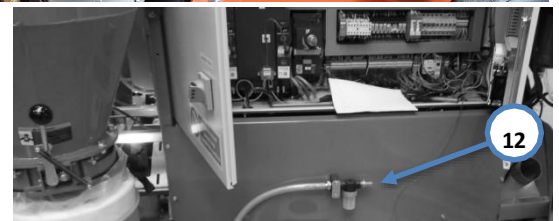



### 5.10 Pre-separator and dust collector

The dust from the grinding heads is transported to 1 point, after which the dust is transported to the pre-separator. The pre-separator will separate up to 95% of the dust into the Longopack disposal system.

The lighter dust is filtered from the air inside the dust collector by 4 industrial size M-class filters. The filters are automatically cleaned every 15 seconds by the pulse cleaning system. The dust from the dust collector falls into a Longopack bag, to easy remove the dust.

After the filtration by the 4 M-class filters, the air goes through the oversized HEPA-filter (H14) which has a filtration efficiency of 99,995% and clean air will exit.



### 5.11 Longopack cassette replacement

Wear a dust mask of at least FFP3 and gloves and make sure to stop the product before you change the longopack.

1. Make sure that the compressor and dust collector are OFF.
2. Close the butterfly valves (1).
3. Remove the Longopack holder (2).
4. Position the new Longopack bag (5) in the support.
5. Cut the clamps (6).
6. Slide out the inner end (7) of the Longopack bag.
7. Slide the outer end (8) out and pull it down over the rim.

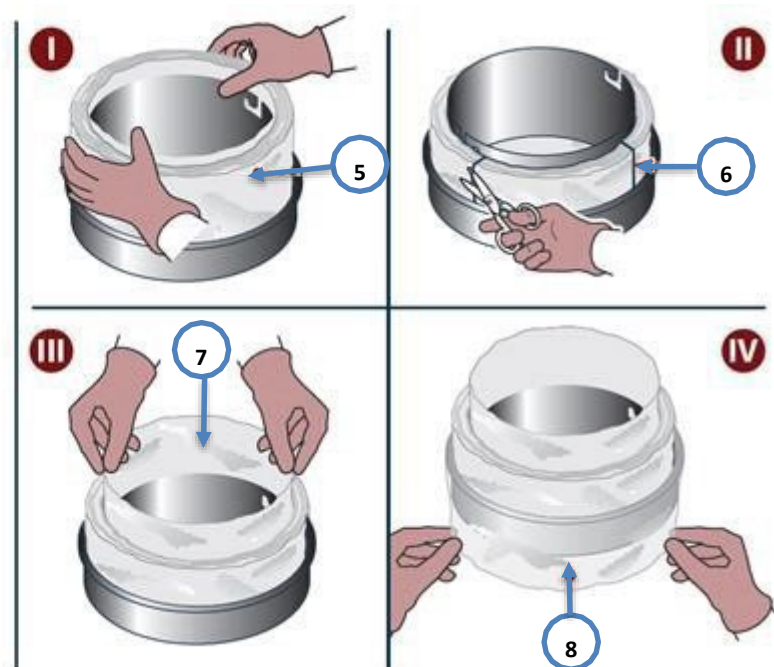
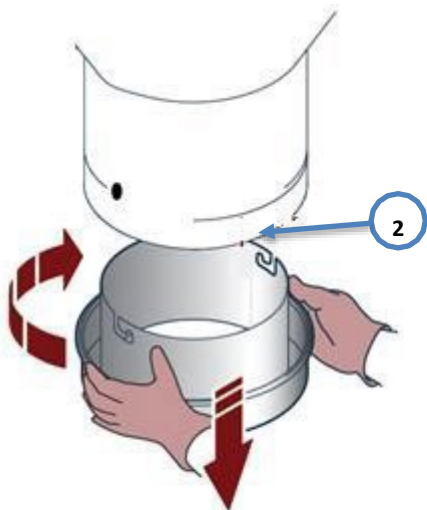
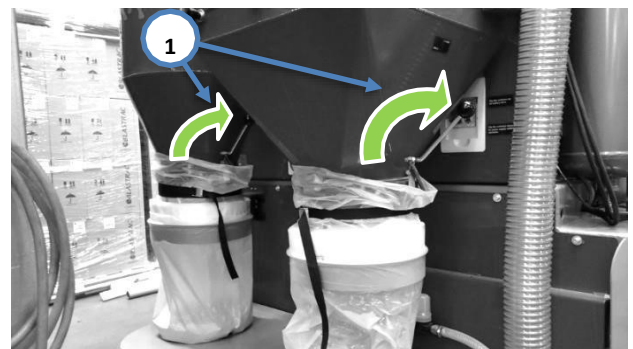

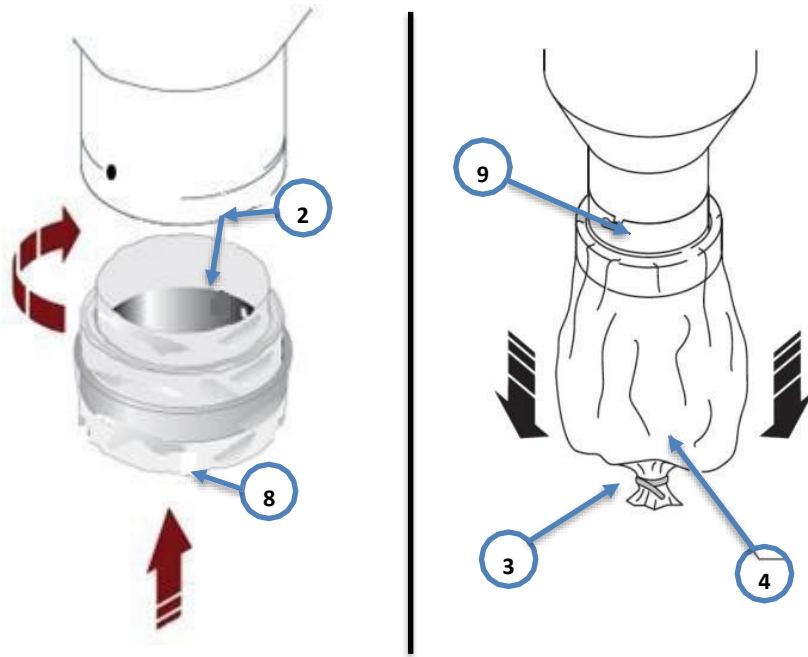

8. Fit the Longopack holder ( 2) back on the machine.
9. Pull the outer end (8) of the Longopack further down.
10. Place the strap (9) around the inner end of the Longopack bag.
11. Tighten the Longopack bag with a clamp (3).
12. Pull out the new section of Longopack (4) about 35 cm / 13 in.

### 5.12 Pulse cleaning system

The M-class filters inside the dust collector are automatically cleaned with the pulse cleaning system. The compressor builds up pressure in the main air tank. From the main air tank the air passes through a spitter-type water separator and a control valve which is set at 7 bar.

The pulse tank has 2 pulse-valves which are alternately activated every 15 seconds. The pulsevalves open shortly, and start a powerful air-pulse to clean the filters from the inside out. A manometer on the outside of the pulse-tank let you to do a check of the correct air pressure in the pulse cleaning system.



The pulse tank has a drain valve to drain condensed water off. Drain the water from the pulse tank every day.

The air pistol on the pulse tank can be used for cleaning.

The degree of pollution of the M-class filters is measured continuously. A warning is pop-up in the touch screen if the filters are almost clogged. The Magnesense gauge indicates the degree of pollution.

### 5.13 Battery monitoring

Note: Make sure that you load the batteries weekly to keep them in good working condition.

The battery monitor is on the control console.

This unit controls the battery status and stops the machine when the battery load has the safe status of 50%.

Battery State of charge	
100%: Healthy DC voltage	50%: ALARM
55%: WARNING	Machine stops
Advice stop machine	Mandatory to switch off
Load the batteries	machine and load the
	batteries



1. If the battery has status 55%, you can see the warning with the visible blue blinking and hear the beep sound.

2. Stop the machine.
3. Set to off the main battery switch at the back and keep the main 3phase voltage.
4. Press any button on the battery monitor to confirm this alarm. The unit will still monitor the battery.
5. When the batteries are not loaded and the monitor reaches the 50% full mark it switches of the main relay that disconnects the battery supply to the control cabinet and forced the machine stop.
6. Load the batteries until the monitor reaches at least the 80% full mark that activates the relay again and set the controls to ON.



You can read from the display the parameters as follow:



Press the "+" button to set the screen to on.  
Press the "+" and "-" buttons again to scroll through display to see the state of charge.



Battery Voltage (V)



Amperage (A) that is flowing out of the battery (negative sign) into the battery (no sign)

or



Estimated time (h) of how long the battery can support the present load until it needs recharging



The power (W) drawn from the battery (negative sign) or flowing into the battery (no sign).



The amount of Ah consumed from the battery

## 5.14 Remote control operation

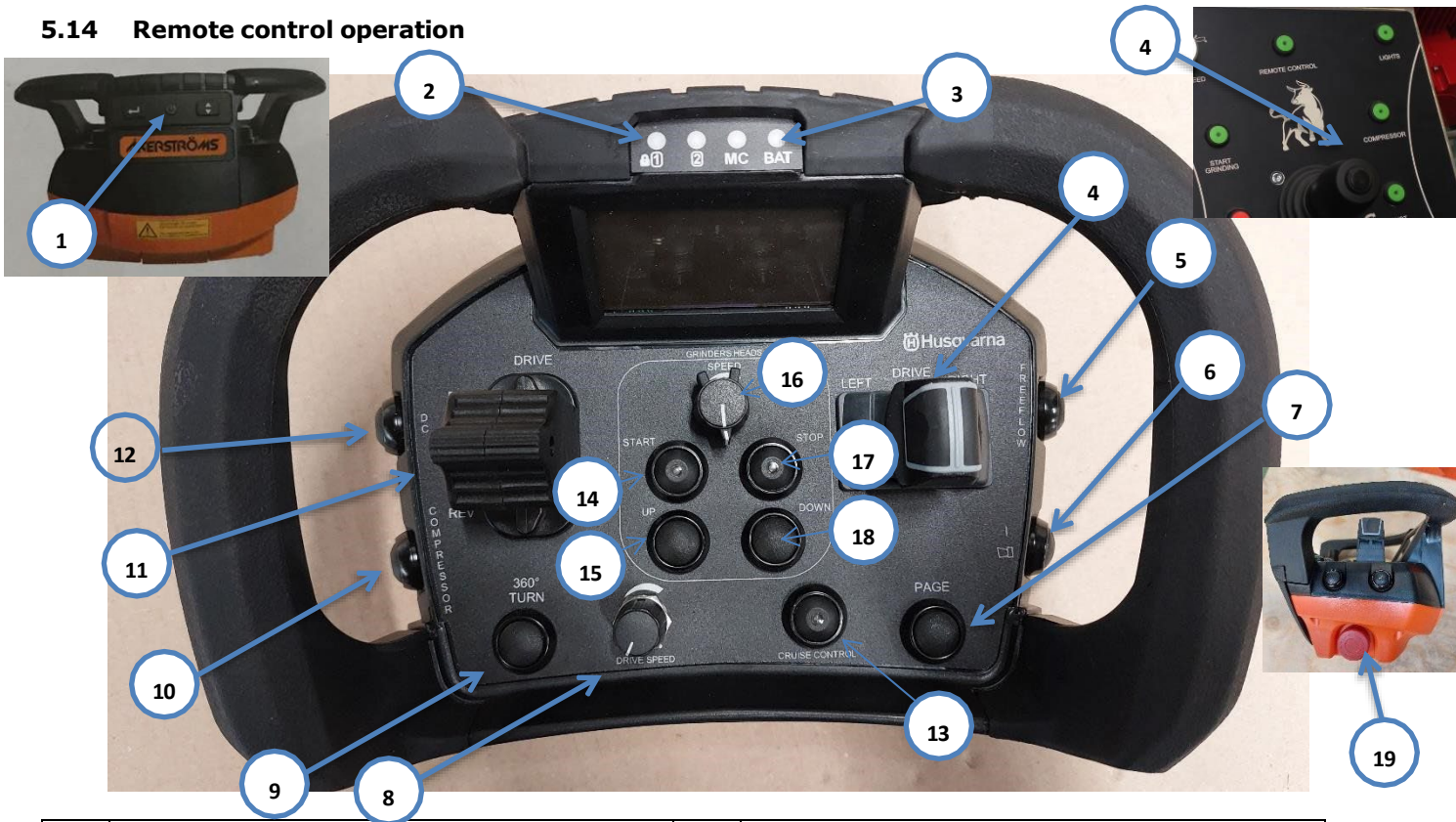

1	ON/OFF button of the remote control	11	Joystick for FORWARD / BACKWARDS driving
2	Pairing indicator	12	Dustcollector ON/OFF button
3	Battery indicator	13	Cruise control
4	Joystick for steering LEFT/RIGHT	14	Start grinding button
5	FreeFlow ON/OFF button	15	Grind heads UP
6	Pairing button	16	RPM speed of the grind heads
7	Scroll page on the remote control screen*	17	Stop grinding button
8	Drive speed button*	18	Grind heads DOWN button
9	Rotate button for 360° turning	19	Quick-stop remote
10	Compressor ON/OFF button		

\* 7:

Page 1: Average speed, Average current, Drive speed.

Page 2: Left grinding head current, Middle grinding head current, Right grinding head current.

Page 3: Left grinding head RPM, Middle grinding head RPM, Right grinding head RPM. Page

4: Main supply pressure, Supply voltage

Persons who are not operating the machine must not be permitted to stay in the surrounding area of at least 15 m from the machine.

Always stop driving first before stop grinding!

1. Push the REMOTE CONTROL button (4) on the control panel.
2. Start the remote control (1) and press the pairing button (6) twice. You can hear a horn every time.
3. When the machine and remote control are paired, the light of the pairing indicator (2) comes on.
4. You can operate the machine with the remote control.

## 6. Maintenance

**Warning:** Use personal protective equipment when you do servicing and maintenance.

**Warning:** Before you do the check, stop the motor and disconnect the power plug from the power supply. Make sure that all drives stop and the machine is cooled down.

**Warning:** Maintenance shall only be done by trained personnel. The electrical cabinet shall be checked only by trained personnel.

**Warning:** High voltage. There are unprotected parts in the power unit. Always disconnect the power plug before you open the door to the electrical cabinet.

Maintenance activities which are not specified in this manual can only be performed by qualified Husqvarna personnel. Speak to your Husqvarna dealer if machine requires servicing.

Before you do any maintenance work you must read and understand the safety chapter.

Failures due to inadequate or incorrect maintenance can generate very high repair costs and long standstill periods of the machine. Regular maintenance therefore is imperative.

Operational safety and service life of the machine depends, among other things, on proper maintenance.

The table below shows recommendations about time, inspection and maintenance for the normal use of the machine.

Operating hours/ time period	Inspection points, maintenance instructions
12 hours after repairing	Do a check of all accessible screw connections for tight seat.
Daily and prior to starting work	Do a check if all safety devices are working adequate. Do a check of the brush sealing for damages and/or wear. Do a check of the hose to the dust collector for damage and obstructions. Do a check of the electric connections for sediments of dirt or foreign bodies. Do a check of the electric motors for dirt and other contaminants. Do a check of the conditions of the wings /discs. Remove water from the air tanks. Do a visual inspection, test and safety checks of remote control transmitter.
Every 48 hours	Clean the complete machine with air. Clean the air filter of the compressor.
Weekly	Do a check of the buffers of the diamond plates. Clean the electrical box inside and outside. Clean the 2 small filters (12, refer to fig. on page 38) of the pressure difference gauge. Clean the outside of the Green 6 48/50 battery charger. Clean the battery contacts and contacts of the remote control transmitter and charger. Clean the remote control panel and check print for readability. Do a check of the HEPA filter. Replace the HEPA filter if it is clogged.
Every 3 months	Clean the complete machine with a damp cloth. Clean the filter of the water separator. Clean and re-lubricate the chains of the drive system. Re-lubricate the 8 bearings of the drive system. Do a check of the chain tension of the drive system. Do a check of the belt tension of the grinding heads.

Every 6 months	Replace the air filter of the compressor. Replace the filter of the water separator. Do a check of the sealing of the butterfly valves and Longopack holders. Clean the cooling ribs / outside of the blower motor.
Annually	Do a full overhaul and clean the complete machine. Replace the remote control parts by manufacturer.

The time indications are based on stopped operation. When the indicated number of working hours is not achieved during the related period, the period can be extended. However, a full overhaul must be carried out at least once a year, consisting of inspection of filters for damage, air tightness of the machine and proper function of the control mechanism. Speak to your Husqvarna dealer for technical inspection. The electrical cabinet shall be checked only by trained personnel. Make sure that the machine is turned off before you open the electrical cabinet.

Pay attention to unusual noises or strong vibrations. Do a check for the cause of every big change. Speak to a technician if you have doubts about the cause or when a repair without a technician seems not possible. Only use genuine Husqvarna spare parts.

There are different working conditions and it is difficult to foreseen the frequency of inspections for wear checks, maintenance and repair works. Prepare a suitable inspection schedule based on your own working conditions and experience. A full overhaul must be carried out at least once a year.

Clean the machine with the dust collector after each usage of the machine. Make sure that there are no wastes or fibre residues in the area of the grinding discs. Our specialists are ready to assist you with more advice.

Prior to any repair works on the machine and its drives, safe the machine against unintentional stop. Disconnect the power supply and main switches.

Follow additional operating and maintenance instructions of Original Equipment Manufacturers if included during your service and maintenance work.

All repair work must to be done by qualified Husqvarna personnel, this to guarantee a safe and reliable machine.

Any guarantee on the machine is automatically void when:

- Non original Husqvarna parts and or diamond discs have been used.
- Repair work is not done by qualified Husqvarna personnel.
- Changes, add items, or conversions are done without the written permission from Husqvarna.

Further is advised:

Store the cleaned and dry machine in a dry and humid-free room. Protect the electrical motor from moisture, heat, dust and shocks.

- Prevent premature wear by keeping the machine as dust free as possible, for these reasons clean the machine regularly with a vacuum cleaner.
- Clean the machine every day with air and non-aggressive materials.
- Never use a high pressure water cleaner to clean the machine.
- Store the cleaned and dry machine in a dry and humid free room. Protect the electrical motor from moisture, heat, dust and shocks.

Work only with original Husqvarna parts.

- Dust in the electrical box can damage the frequency inverter. Clean the electrical box every day from inside and outside.
- Clean the fans and filters from the inside of the electro box with compressed air and a vacuum cleaner towards the outside air.
- Do a check regularly to see if the diamond wings are in good condition. Replace immediately when these are damaged or worn out.

### 6.1 Buffers

Do a weekly check if the diamond plates have too much space in the buffers.

If the diamond plate has too much space, replace complete buffer plate.

Standard the buffer plates are delivered with 4 shock absorbers. You can add 4 more absorbers to have 8 absorbers at all. Always mount the tool holder with screws, position 5.

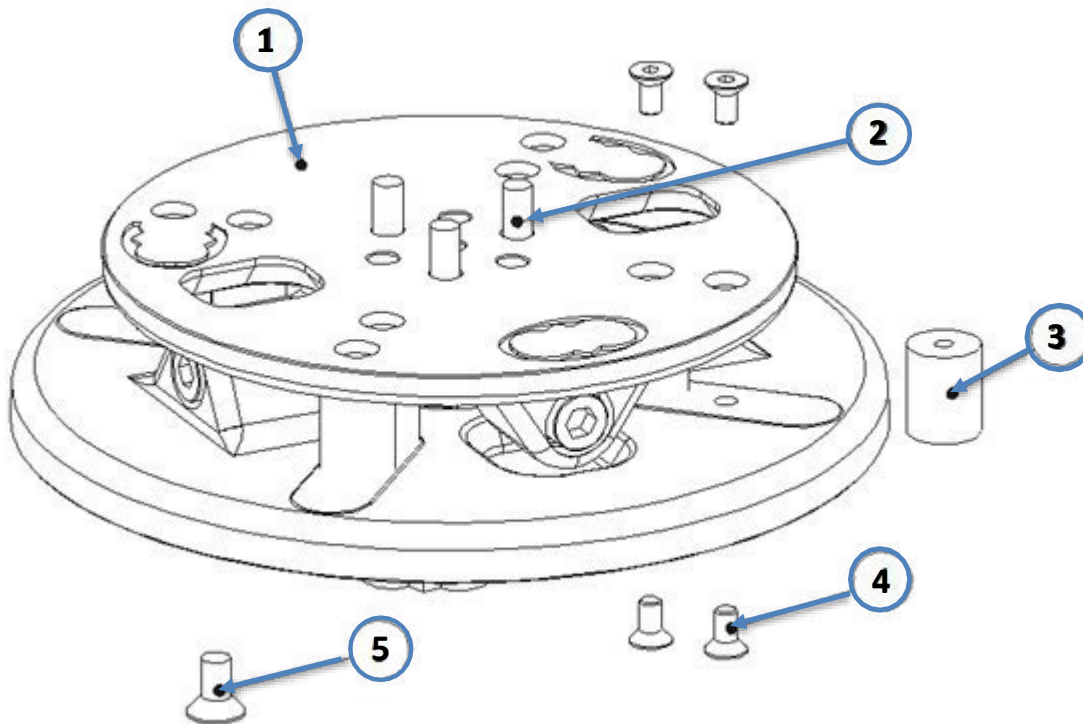

Item	Part number	Description	Qty. (x3 per machine)
1	E10172-240MM	Buffer complete	1
2	BE0011	M8x20 hexagon socket head cap screw	3
3	E12065	Shock absorber	4 / 8
4	BE0955	M6x12 hexagon socket countersunk 10.9	8 / 16
5	BE0456	M8x16 hexagon socket countersunk	3

### 6.2 Main air tank

The main air tank (10) is filled by the compressor from point (6) and through water separator (5).

On top of the main air tank is a safety valve and at the bottom a control valve. The control valve (11) is set at 8.5 bar and the safety valve (8) is set at 10 bar. The pressure in the main air tank is visible on the manometer (4).

If the safety valve (8) blows air during normal operation, do a check of the control valve (11) and adjust it.

From the main air tank one connection goes to the pulse system, through the water separator (2) and control valve (1) of the pulse system, to the pulse tank (3).

The main air tank also has an external connection (9) for maintenance purposes. An external compressor can be connected to the system via this connection.

Drain valve (7) drains water from the system. Use the drain valve every day.

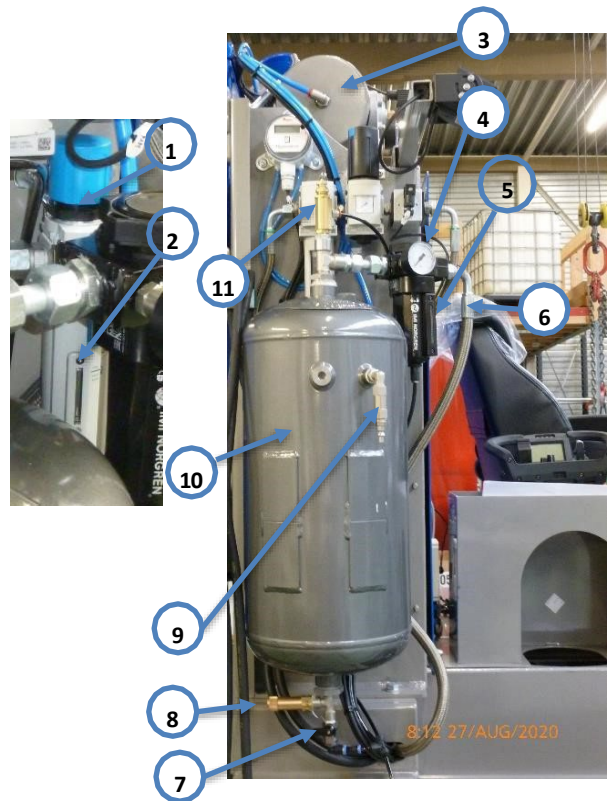

The second connection from the main air tank goes to the lifting control of the grindheads. From the lifting control, the pneumatic lifting cylinders are controlled to lift and lower the grindheads.

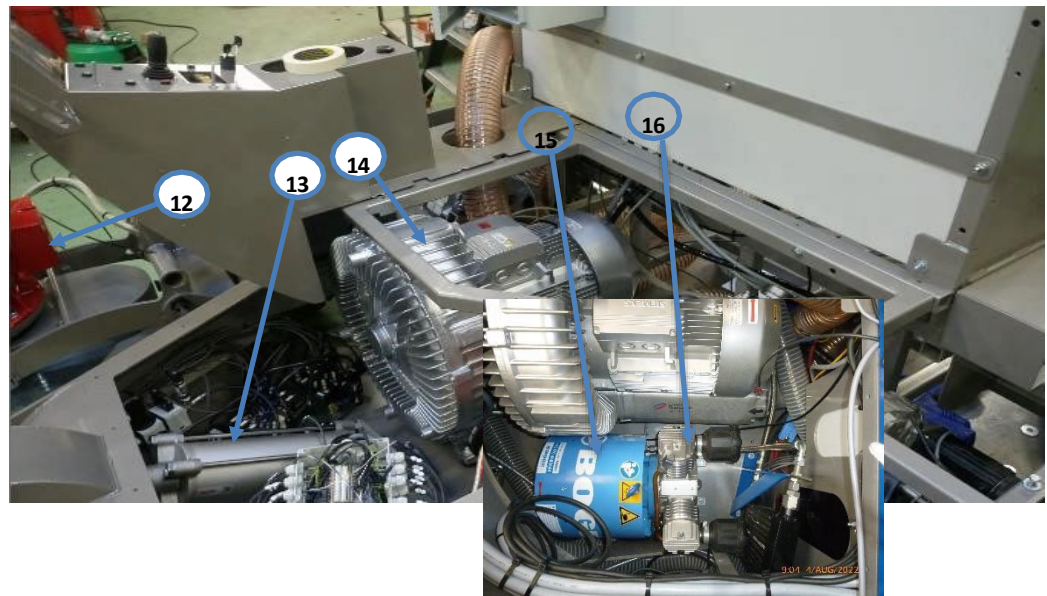

Item	Description
12	Grindhead RIGHT
13	Lifting cylinder grinding head MIDDLE
14	Blower motor DC
15	Motor for compressor
16	Compressor



### 6.3 Compressor

The compressor (16) is driven by 1.5 kW electromotor (15). Refer to fig. on page 36.

Clean the air filter (17) of the compressor every month. Only use air to clean the air filter. Replace the air filter at least once every year or 3000 working hours (whichever comes first).

Do a check of the cooler (18) of the compressor and clean it at least once every year or 3000 working hours (whichever comes first).

Do a check of the safety valve (19) at least once every year or 3000 working hours (whichever comes first).

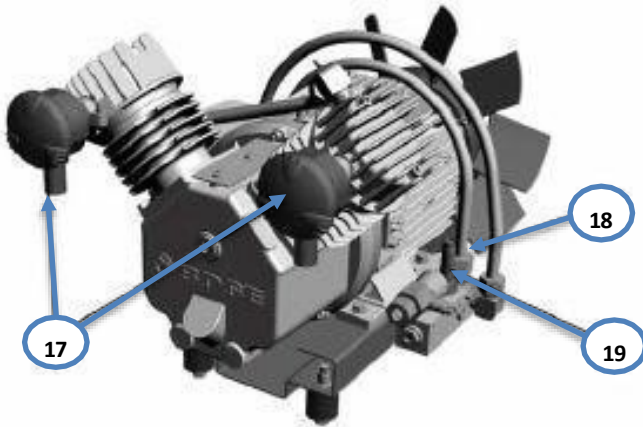

If the compressor does not keep the required working pressure or becomes too hot, do a check of below parts:

- Suction filter
- Rotating direction
  
- Dirty cooling ribs
- Valves and seals
- Leaks in the system
- Drain valve for water release

Before you remove any part of the compressor:

- Make sure that the compressor cannot start.
- Make sure there is no pressure in the system.

To clean or replace the filter cartridge, proceed as follows:

1. Remove cladding/cover.
2. Remove filter case cover
3. Take out the filter cartridge.
4. Clean/change filter cartridge.

To clean the filter cartridge:

1. Tap the filter cartridge with your hand to knock out coarse dust.
2. Remove the dust with dry compressed air (maximum pressure 5 bar) from the inside outwards.
3. Clean the sealing surfaces of the filter cartridge.

To insert the filter cartridge:

Insert the cleaned or new filter cartridge as follows:

1. Insert the filter cartridge into the filter case.
2. Fasten the filter case cover.
3. Fit the service side cladding.

For more information about the maintenance refer to the Boge manual.



*Suction filter and filter cartridge*

## 6.4 Pulse system

The dust collector has an air pulse cleaning system which increases the life of the filter cartridges and keep a constant suction power.

The pressurized air supplies an air pulse which cleans the filters from the inside. With every pulse the dirt and dust is removed from the filters after it falls into the Longopack bags.

- After each day relief the pressure and drain the water from the pressure tank with the air pistol and the drain valve on the pulse tank (4).
- Regularly clean the 2 small filters (12) of the pressure difference gauge. At least once per week.

If you temporarily stop the work (1/2 hour – 1 hour), or you stop the machine for a long time:

1. Set the Dust Collector Speed (8) to LOW and make sure that the compressor is ON (7). Pulse cleaning of the filter system will continue and will increase the life-time of the filter cartridges.

Remove water from the air tanks before you stop the machine for a long time.

The pressure in the system is between 7 and 9 bar in normal mode. It is regulated by the control valve (10).

The safety valve installed on the compressor is activated at approximately

10 bar. The safety valve (5) on the main air tank is activated at approximately 10 bar. These provisions are to ensure that when there is a defect, the pressure remains within safe limits.

If the safety valve (5) regularly vents air, than probably the pressure control valve (8) must be re-adjusted!

Only a skilled Husqvarna technician performs this action, speak to Husqvarna for help.

If the pressure of 7 bar is not reached, there can be a leakage in the pneumatic circuit. It can be also dirt in the filter of the water separator or in the air filter of the compressor. Refer to chapters 6.3 Compressor and 6.6 Water separator for maintenance instructions.

If the water separator and compressor are not contaminated, it is possible that there is a leakage in the air tubing, or the pressure control valve is damaged. In that case replace the damaged parts or have speak to Husqvarna for servicing.

When there is a pressure but the pulse system does not operate, there can be a failure in the electrical system which controls the pulsing system. Do a check of the hoses and connectors, and do a check of the electrical wiring for damages. Check the pneumatic hoses regularly.

Do a check the wiring and the PLC-settings.

It is recommended to speak to Husqvarna Support to prevent the operational problems.

### PLC Pulse timer unit

The pulse timer unit controls the air pulse system. This unit is at delivery of the machine already programmed with regard to optimal filter cleaning. If, however doubts arise about settings, this unit can be checked. We advise to contact Husqvarna support in order to prevent operational problems.

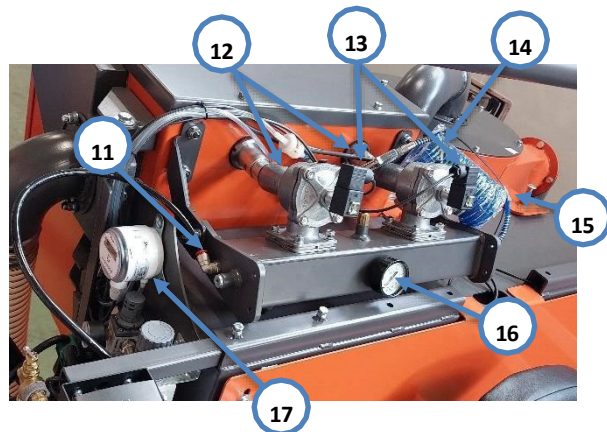
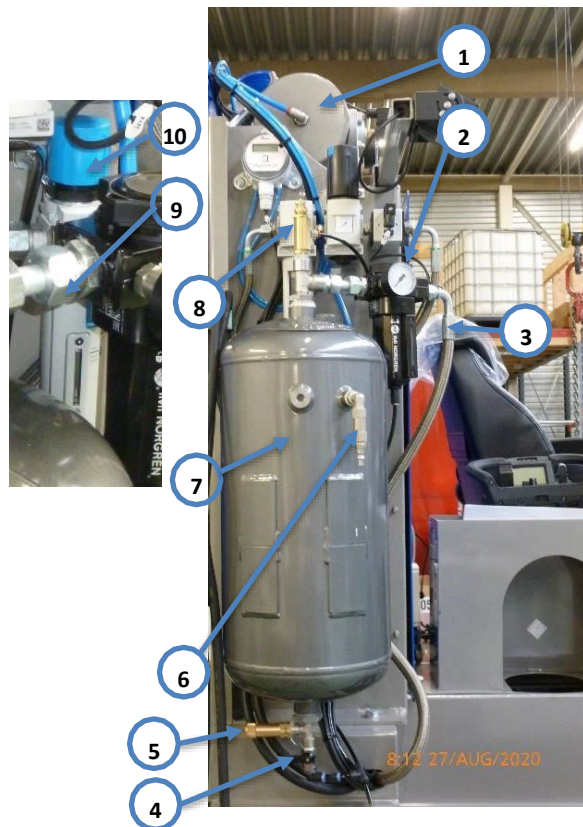

**After each day, let the pulse system run for 10-15 minutes with the lowest speed of the fan, to clean the filter cartridges.**

## 6.5 Water separator

The water separator (5, refer to fig. on page 36) filters dirt particles, oil and water from the air. It is recommended to replace the filter after every 450 operating hours.

Never remove the water separator from the pulse system. The water separator keeps the pulse system from clogging up with oil, dirt and water.

1	Cover
2	Rotary knob
3	Plastic bowl
4	Metal bowl
5	Filter element
6	Spin disc
7	Filter holder
8	Separating plate
9	Stabilising disc
10	Diaphragm
11	Spring

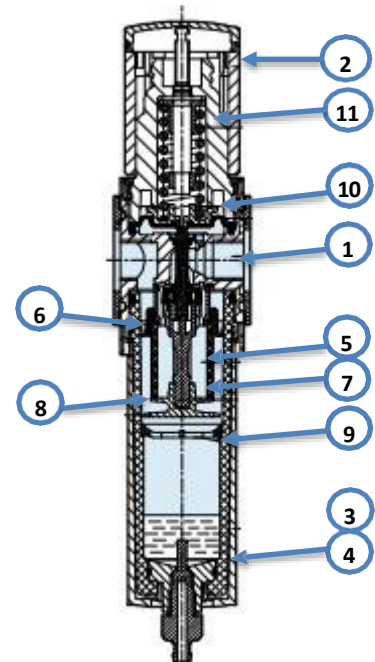

Do a check of the filter:

When condensate level reaches approximately 10 mm below the filter element (5) filter/water separator empties automatically. It is also possible to empty manual by turning the drainage screw (9) counterclockwise direction as seen from below.

The separated water is drained underneath the machine.

Replace the filter cartridge if below signs show:

- Low flow despite unmodified pressure setting
- Drop in pressure:  $\Delta p$  greater than 0,35 bar
- It is recommended to replace the filter after every 1000 hours.

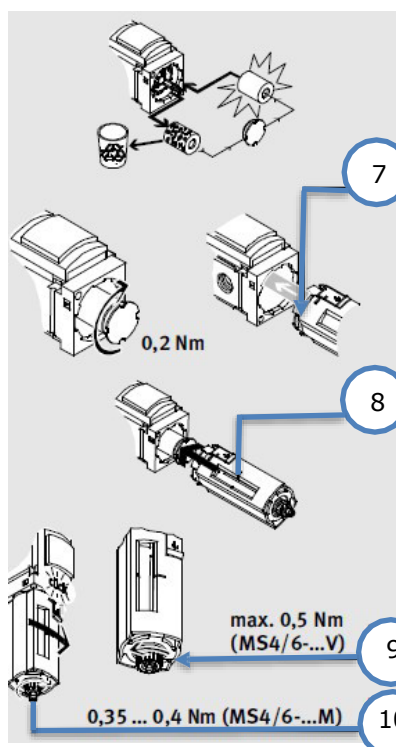

### Filter replacement

1. Exhaust the unit.
2. Push the unlocking slide (5) in the direction of the arrow.
3. Turn the filter bowl counterclockwise.
4. Pull the filter bowl away from the unit
5. Turn de filter plate (6) counterclockwise.
6. Grasp the new filter cartridge only at the lower end. A support span is fitted in the new 5 $\mu$ m filter cartridge.
7. Tighten the new filter cartridge hand-tight.
8. Fit the individual parts again in the reverse sequence.
9. Do a check if the locking pin (7) of the filter bowl is in direction to the large recess in the housing.
10. Make sure that you hear a click sound of the unlocking slide when the end stop is reached.

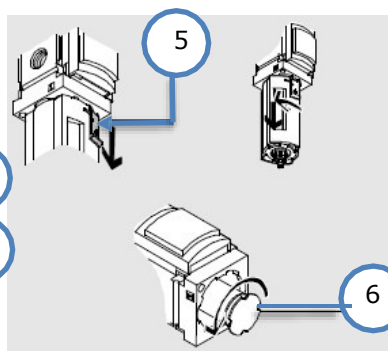

The fully automatic condensate drain (water separator), the valve opens automatically as soon as the floater is in the highest point. The valve closes automatically when the floater reaches the lowest point.

To set to automatic mode, turn the drain screw fully to the right (left thread!).

Note: If the screw is installed completely, the automatic drainage is blocked.

To drain the water separator manually If the automatic water separator drain does not respond and the condensate reaches the upper mark (4), the condensate must be drained manually.

1. Turn the drain screw (5) fully to the left.

Setting pressure

1. Pull cap (6) upwards.
2. Turn the cap to set the pressure.
3. Press cap (6) down. The pressure regulator is now fixed.

Note: Never change the pressure settings unless you have explicit permission from the Husqvarna technician.

The safety hooks must be completely retracted if reset the pressure.

## 6.6 Filters maintenance

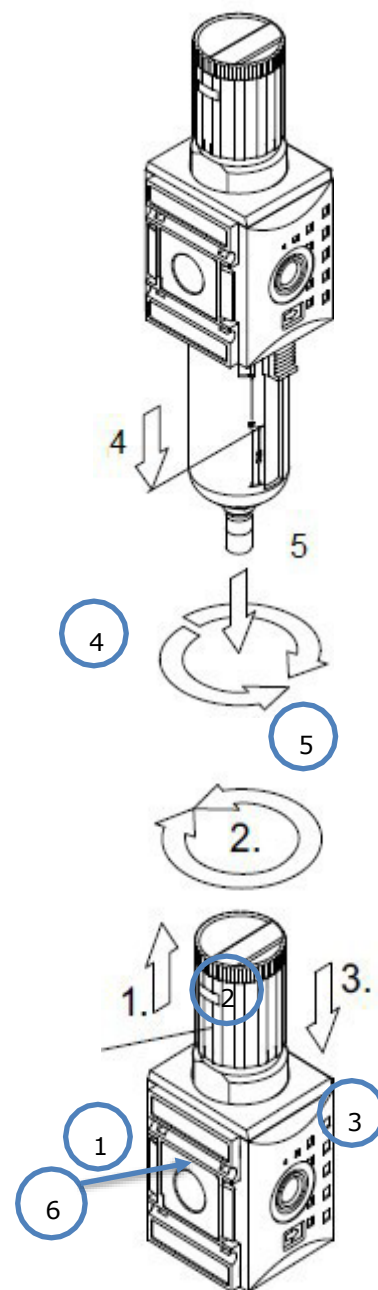

Observe the pressure difference gauge.

When the pressure difference gauge is above 1.9 kPa (20 cm H<sub>2</sub>O), the filters are probably clogged.

If the dust collector loses suction power, do the steps as follow:

1. Do a check of all dust hoses and connections for damages and obstructions.
2. Make sure that the Longopack bags are empty.
3. Make sure that the compressor is fully pressurized and set it to off.
4. Remove all moisture from the main air tank with the drain valve.
5. Turn on the compressor until it is fully pressurized again, now remove all moisture from the pulse air tank with its drain valve.
6. Turn on the compressor until it is fully pressurized again, now use the air gun to completely empty the pulse tank.

7. Only turn on the compressor and keep the fan unit turned off. Close the butterfly valves of the preseparator and dust collector. Make sure that there are Longopack bags underneath the dust collector and pre-separator. Let the machine pulse for about a half an hour to clean the filters from the inside.

When the magnesense meter indicate more than 1.9 kPa (20 cm H<sub>2</sub>O), it means that a filter is damaged or not fitted properly inside the filter chamber.

1. Do a check if the filters are damaged or installed incorrectly.
2. Replace the filter.
3. Clean thoroughly the compartment above the filters and the connection of the air hoses.

Do not continue the work with a damaged filter or if there is a leakage. It can cause serious damage to the machine and is a health hazard!

Never expose the filter cartridges to moisture!

CUW Cartridge Filter  
IFA/BIA certificate M-class

Order nr. E10600

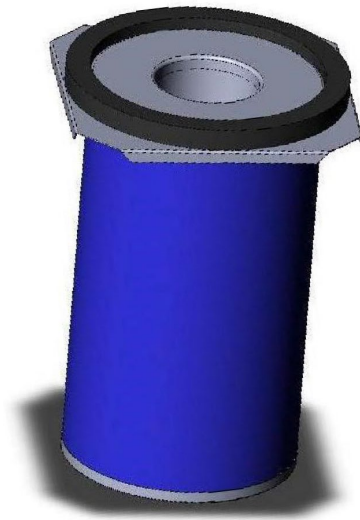

## 6.7 Filter replacement

**Warning:** Always put on a personal protective equipment, the dust can be hazardous to the health!

- Make sure that the machine is turned off.
- Always put on gloves and a dust mask of at least class FFP3.
- Use an extra vacuum cleaner to work as dust free as possible.

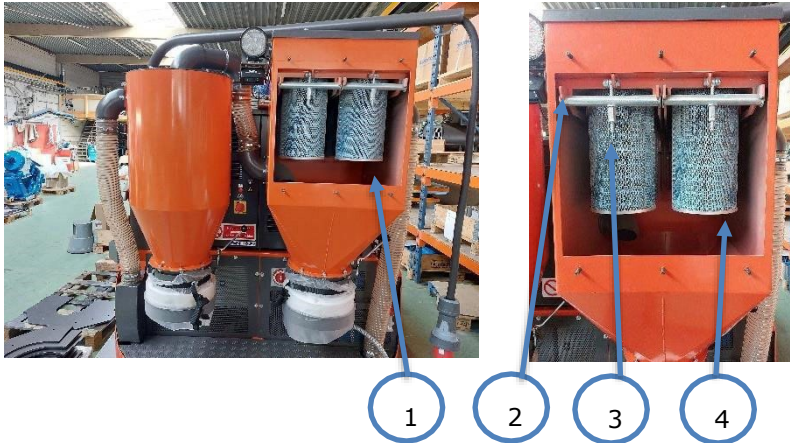

Make sure that you have enough sturdy plastic bags or use big bags for the disposal of the old filters. Observe the national regulations in force both during exchange and disposal of the old filters.

1. Open the maintenance door (1) of the filter unit in order to get access to the filter cartridges.
2. Loosen the nut and washer (3).
3. Remove the locking bar (2).
4. The filter bracket is tilted down and you can take out the filters easily.
5. Remove the filter (4) and put it in a sturdy plastic bag.
6. When you install the new filter cartridges make sure that their gaskets at the upper side are firmly attached to the sheet steel of the filter chamber. A tilt of the filter cartridge causes the leakage. The suction of contaminants is in the clean part and blow them in the outer air backwards.
7. If a filter is damaged, has leakage or is installed incorrectly, replace the filter. The compartment above the filters, the connection of the air hoses and the silencer also have to be cleaned thoroughly.
8. If the HEPA-filter blows out dust, stop the machine immediately! This means probably that a filter is damaged or not fitted properly inside the filter chamber. Do a check of the filters and replace if necessary.

## 6.8 Blower motor

The dust collector has the powerful 13.8 kW blower motor (1).

The inlet is equipped with a limit valve (2) to safe the blower motor. If you change the settings of this limit valve, it will void any warranty.

From the inlet of the blower motor a dust hose goes to the upper part of the dust collector where the air goes through the filters.

From the dirty side of the filters is a connection from the upper part of the pre-separator.

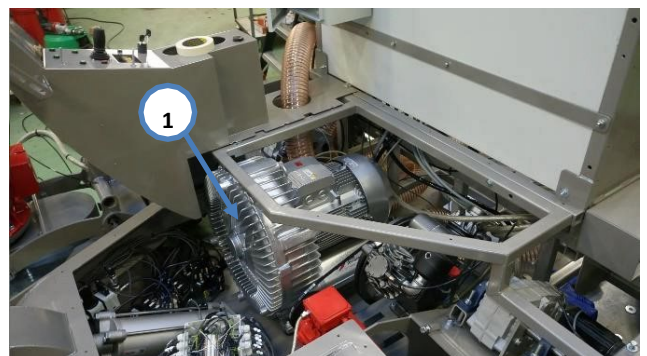

From the side entrance of the pre-separator is a dust hose to connect the junction (3) of the 3 dust hoses from the 3 grind heads.

The outlet of the blower motor blows the air through the oversized HEPA-filter, that cleans 99,995% of the airborne particles 0.3 micrometers ( $\mu\text{m}$ ) in diameter.

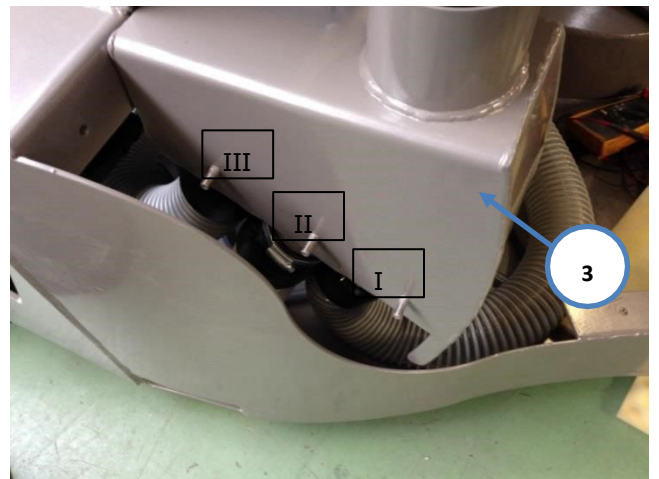
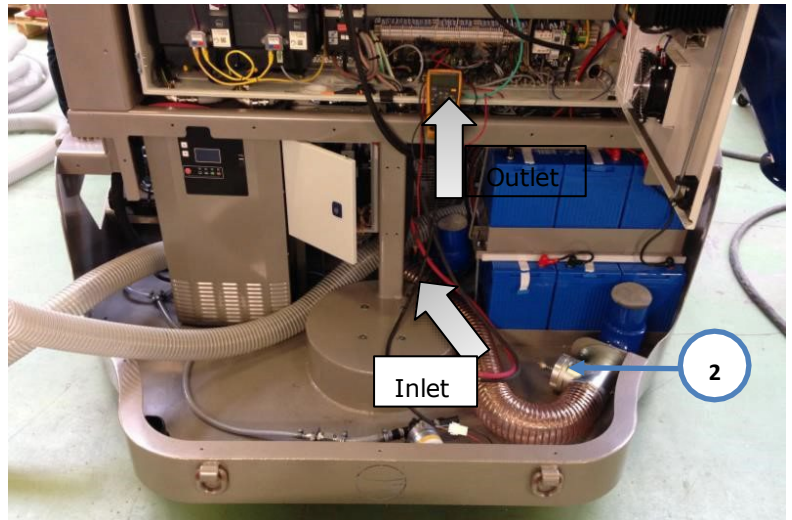

The connections in the junction (3) are:

- I = Grind head LEFT = Lowest connection
- II = Grind head MIDDLE = Middle connection
- III = Grind head RIGHT = Highest connection

## 6.9 Drive system

The BMG 2200RC is driven by 2 Heinzmann High Torque Wheel Hub Drives. It has two electronic controllers that are operated with the joystick and buttons from the control or remote panel.

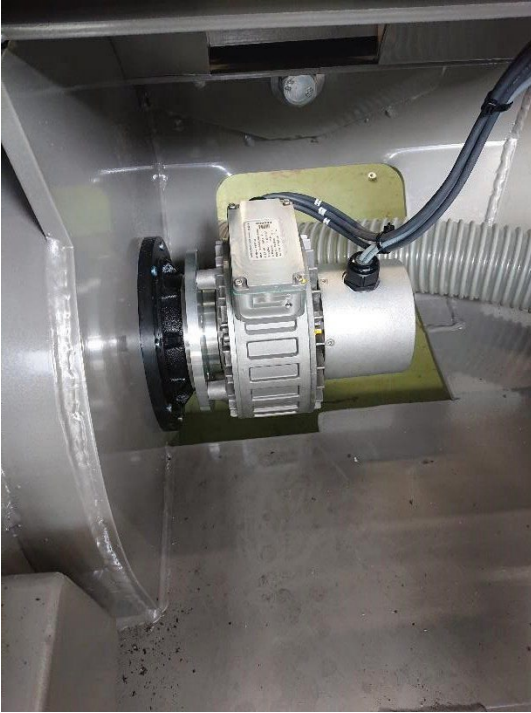

The motors are equipped with a holding brake and manual release so that the wheels can rotate freely without the brake. The rims are directly installed to the motor.

### **To operate the manual release**

Make sure that the wheels have wheel blocks in front and back of them before the manual release. The wheels can roll freely when you start the manual release.

Release the wheels manually on ramp only if there is no possibility to move it when machine works. Make sure that there are no persons or obstacles on the route you are going to move the machine to. It can cause serious injury or dead.



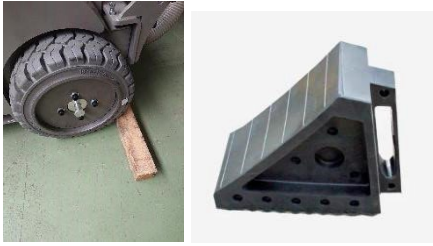

The driving of the machine cannot be operated from the controls when the wheels are released. The function of the holding brakes is mechanically by-passed.

To move up or put on ramp the machine, speak to outside company that have appropriate experience.

1. Pull the knob that is in the center of the rim.



2. Pull the knob and move a little the wheel to release easily.



3. Make sure that the knob is fully pulled out. Turn the knob to keep it in the position.
4. Do the same for the other side to let the machine moves freely.



## 6.10 Maintenance of the battery charger Green 6 48/50

- The batteries are charged automatically when the machine is connected to the main power.
- The BMG 2200RC is equipped with the HF E 48-50 high frequency traction-battery charger.
- Do not expose the battery charger to rain, water splashes, steam or other form of liquid.
- Keep the battery charger as dust free as possible.
- To reduce risk or injury, only charge Husqvarna approved batteries. Do not charge other types of rechargeable or non-rechargeable batteries as they can explode and cause damage or injury.
- Do not open the battery charger because there are no parts which can be serviced and/or replaced.
- Only specialized personnel, authorized by Husqvarna servicing can open the device.
- Electrical / electronic components inside can cause electric shocks even if the device is disconnected.
- Disconnect the machine from the mains before you clean the charger or connect and disconnect the batteries.
- During normal operation of the battery charger, the external surface is hot and can stay hot for a certain period of time after the machine is stopped.
- Special maintenance is not required for the battery charger, only regular cleaning procedures. It is recommended to use pressurized air to blow the inside of the charger clean from accumulated dust.
- Clean the battery charger every week or more often if the work area is very dusty.
- DO NOT use water and / or detergents of any kind to clean.
- The USB port is a servicing port to set the parameters of the charger and download the historical data and graphs.

### Visual signals on the charger

REF	Description	DL4 LED (green)	DL3 LED (yellow)	DL 2 LED (green)	DL1 LED (red)	Display
S1	Power supply from battery only	OFF	OFF	OFF	OFF	OFF
S2	Power supply from mains only	OFF	OFF	OFF	OFF	ON
S3	Power supply from mains and battery	ON	OFF	OFF	OFF	ON
S4	Auto start execution	Blinks	Blinks	Blinks	Blinks	ON
F1	Phase 1 – Initial Charge CI	Blinks	OFF	OFF	OFF	ON
F2-F7	Phase 2 – Phase 7	Blinks	ON	OFF	OFF	ON
F8	Equalization period	ON	ON	ON	OFF	ON
EQU ON	Equalisation charge ON (in operation)	Blinks	Blinks	ON	OFF	ON
EQU OFF	Equalisation charge OFF (in standby)	ON	ON	ON	OFF	ON
M	Maintenance	Blinks	Blinks	ON	OFF	ON
END	Charging Finished	ON	ON	ON	OFF	ON

## Display LCD

The battery charger has 3 monitor menus. Use the P2 button to navigate between the menus.

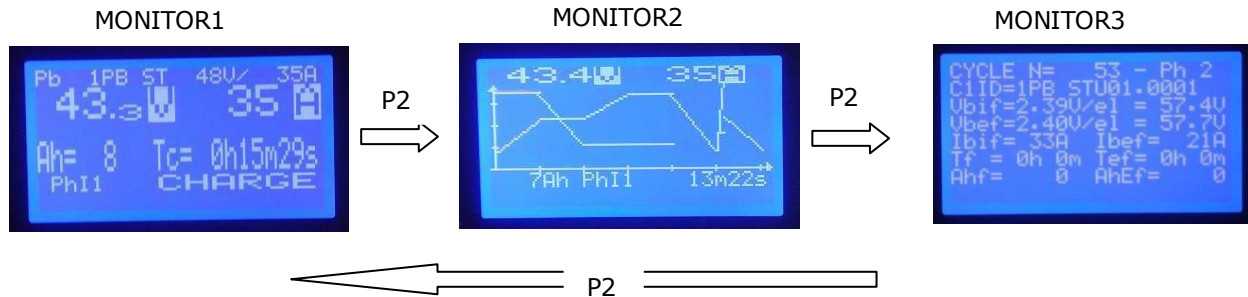

Next is a summary of the information reported respectively in the 3 MONITOR displays.

### MONITOR1

Row	Example	Description
(1)	Pb 1Pb ST 48V /35A	Technology of the battery, type of curve, size of the battery charger
(2)	43.3 V 35A	Battery voltage and current
(3)	Ah= 8 Tc= 0h15m29s	Ah charged, charging time in hours, min, sec
(4)	PhI1 CHARGE	Current charging phase, status of the battery charger (for example phase = auto start A0, Status= BATTERY NOT CONNECTED)
(5)	-- Messages	Possible fault or status messages

### MONITOR2

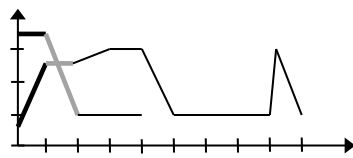
Row	Example	Description
(1)	43.4V 35A	Battery voltage and current
(2)		Active charging profile as follows: Phase completed (bold line) Current phase (flashing line) Phase to conduct (thin line)
(3)	7Ah PhI1 13m22s	Ah charged, charging time in hours, min, sec
(4)	-- Message	Possible fault or status messages

### MONITOR3

Row	Example	Description
(1)	CYCLE N= 53 - Ph 2	Number of charging cycle and current charging phase For example charging cycle 53 and phase 2
(2)	C1ID=1PB ST_01.0001	Unique code of the charging curve
(3)	Vbif=2.39V/el = 57.4V	Battery voltage at the beginning of the phase (Vbif) first expressed as element voltage (V/el) and then as absolute voltage (V)
(4)	Vbef=2.40V/el = 57.7V	Battery voltage at the end of the phase (current phase) (Vbef) first expressed as element voltage (V/el) and then as absolute voltage (V)
(5)	Ibif= 33A Ibef= 21A	Current at the beginning of the phase (Ibif) and current at the end of the phase (Ibef)

(6)	Tf = 0h0m Tef=0hm	Time of the individual phase (Tf) and Overall charging time at the end of the phase (Tef)
(7)	Ahf= 0 AhEf = 0	Ah output in the selected phase Ahf) and overall charged Ah (AhEf)
(8)	-- Message	It reports any faults that took place during the charging cycle

### 6.11 Battery maintenance

The machine is equipped with 6 batteries 4 GBV 180 EV 8 Volt, 180 Ah.

They are sealed, maintenance-free batteries that are non-hazardous, non-spillable and are made from ~80% recycled materials. During normal operation batteries do not release any harmful gasses and there is no leakage of acidic electrolyte into the environment.

Only use Husqvarna approved batteries. Husqvarna cannot guarantee the safety of the machine when other batteries are used.

**Warning:** Only trained personnel servicing the batteries. High amperage exist and can cause serious injury or death. Immediately flush eyes with cold, fresh water for a minimum of 10 minutes if electrolytic acid comes in contact with eyes. Seek professional medical attention immediately.

Use isolated tools when you replace battery or do the maintenance.

Do not wear jewellery like rings, watches, necklaces etc. if you work with batteries. They can cause a serious burns. Batteries are heavy (around 37 kg). When you remove batteries, ask someone for help or use a lifting device. Do not drop.

Risk of electrical shock. Do not connect the battery terminals to keys, screws or other metal objects. This can cause a short circuit of the battery.

If you replace the batteries, make sure that use the wiring diagram in the service manual. Do not mix new batteries with the old batteries in the machine. It is recommended to replace all batteries at the same time. The batteries contain lead-acid, do not disassemble, heat above 60°C, or incinerate. The old batteries not domestic waste. Batteries contain harmful materials, for example lead and sulphuric acid. These materials form an environmental and health hazard. It is not permitted to dispose this product as normal household waste. Obey the local recycling requirements and applicable regulations.

### 6.12 To replace the batteries

#### Remove the batteries

1. Make sure the tools are good isolated. If they are not this can result in serious damage, injuries or dead.
2. Disconnect all the wires from the top batteries.
3. Take the lit for the side of the top container.
4. Remove the top batteries.
5. Remove the container.
6. Disconnect all the wires of the lower batteries.
7. Remove the lower batteries.

#### Install the batteries

1. Make sure the tools are good isolated. If they are not this can result in serious damage, injuries or dead.
2. Place the lower batteries.
3. Connect the batteries as shown in the drawing.
4. Place the isolation and container.
5. Place the top batteries.
6. Close the lit in the container
7. Connect the top batteries as shown in the drawing.

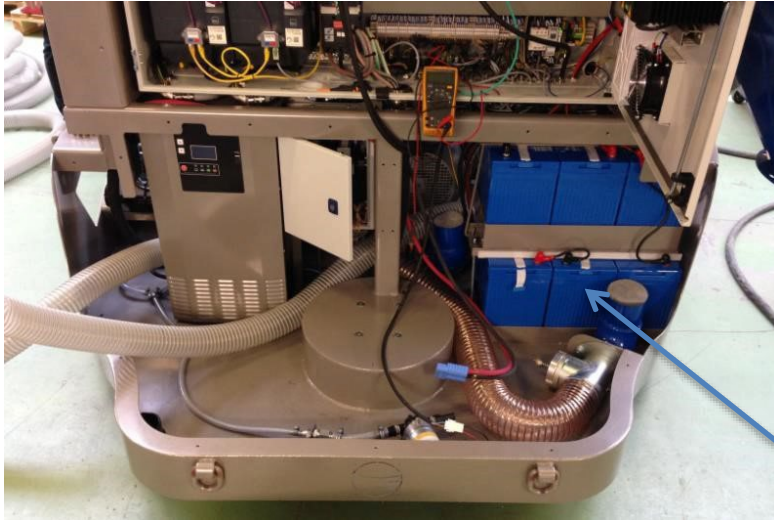

6x Part number:  
E09174 - Battery

The temperature of work is important for batteries. Optimum range is from -10°C to 45°C. Do not keep the batteries in a minimum temperature for a long period of time. The batteries can freeze in low temperature. Never charge a frozen battery. More characteristics are shown in the table below.

CHARACTERISTICS		
<b>Capacity</b> 77°F (25°C)	20 Hour Rate (8A to 7.0 Volts)	160AH
	10 Hour Rate (14.4A to 7.0 Volts)	144AH
	5 Hour Rate (26.2A to 6.8 Volts)	131AH
<b>Internal Resistance</b>	Full charged Battery 77°F (25°C)	2.4m Ω
<b>Capacity Affected by Temperature</b> (20 Hour Rate)	104°F (40°C)	102%
	77°F (25°C)	100%
	32°F (0°C)	85%
	5°F (-15°C)	65%
<b>Self-Discharge</b> 77°F(25°C)	Capacity after 3 month storage	91%
	Capacity after 6 month storage	82%
	Capacity after 12 month storage	64%
<b>Max. Discharge Current</b> 77°F (25°C)	2000A (5s)	
<b>Terminal Standard</b>	M8	
<b>Charging</b> (Constant Voltage)	<b>Cycle</b>	Initial Charging Current $\leq 0.2 \times C20$ 9.67 V ~ 9.93 V/77°F (25°C)
	<b>Float</b>	9.06 V ~ 9.2 V/77°F (25°C)



NONSPILLABLE



Pb



Pb

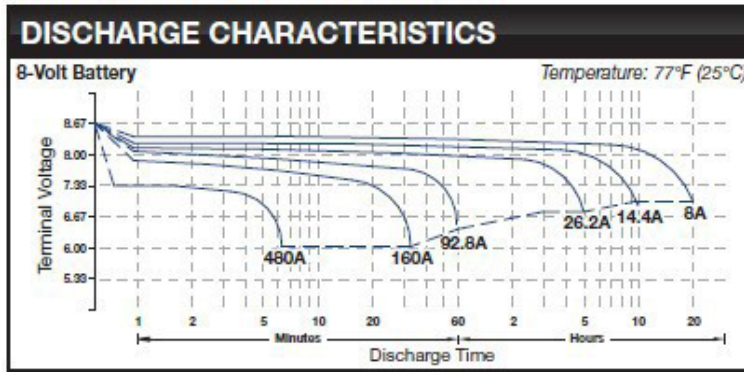

CONSTANT CURRENT DISCHARGE (Amps)											
CUT OFF VOLTAGE V/cell	30M	45M	1H	2H	3H	5H	8H	10H	12H	20H	24H
1.75V	150	110	90.2	56.1	39.2	25.7	17.4	14.4	12.3	8.0	6.8

RESERVE CAPACITY	
@25 AMPS	@56 AMPS
315 Minutes	112 Minutes

### 6.13 Remote control maintenance

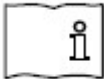

Always refer to the safety, service and maintenance instructions from the manufacturer of the remote control for all information.

To keep availability and operational safety, a regular maintenance is necessary on the system.

#### Daily maintenance

Before each use of the transmitter, do a check of the below parts for faults or damages:

- Visual inspection of rubber sealing around levers
- Broken/faulty switches or controls
- Visual inspection of transmitter housing (cracks, dents)
- Visual inspection of carrying device
- Test of battery lock is working normally
- Test of manual stop button (it shall be intact and easy to move)

Do a check of the functions:

- Do a check of the function of transmitter LED signals, short flash at power up.
- Do a check of the function of transmitter "Tilt function". Tilt the transmitter 90 degrees out of normal carry position.

When the remote control is tilted the machine stops.

If there is any damage or fault contact an authorised service technician. After every workday, use air to blow the dust off the transmitter.

## Weekly maintenance

- Clean the battery contacts and the contacts on the transmitter and charger. Do not use any aggressive cleaning materials!
- Clean the transmitters control panel and do a check that the print is still readable. Do not use any aggressive cleaning materials!

## Yearly maintenance

To keep availability and operational safety, the yearly maintenance is necessary on the system. Only personnel trained and qualified by Akerströms can perform the scheduled maintenance.

The maintenance is divided into a yearly check and an every 4th year check.

- Visual inspection of assembly Yearly
- Replacement of seal boots for switches Yearly
- Replacement of detent springs in joystick Every 4th year
- Replacement of bellows for joystick Yearly
- Replacement of stop switch Yearly or after 7600 cycles,

Do not operate the product with a damaged remote control. Even initially minor damage can cause a damage extension and higher costs of repair.

### 6.14 Maintenance screen

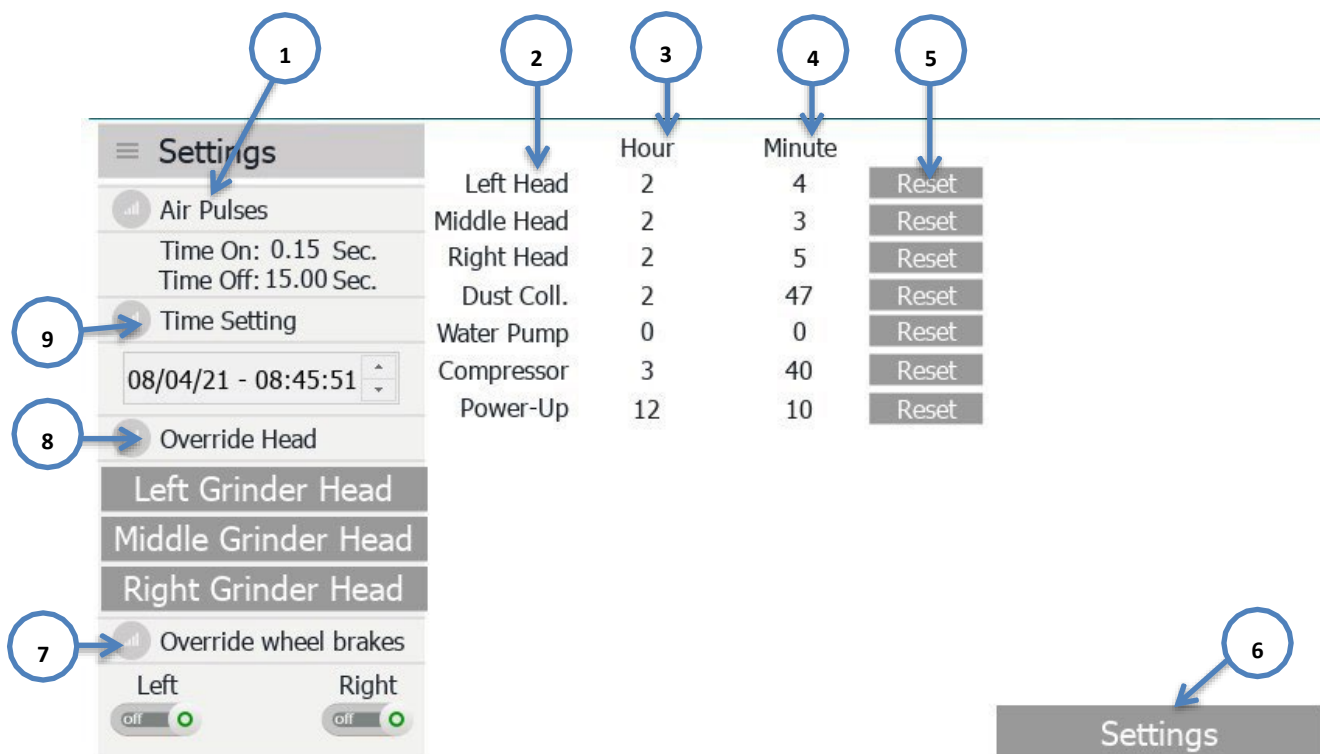

1	Air pulse settings	6	Back to settings menu
2	Description of machine item	7	Override wheel brakes
3	Hour counter of section	8	Override head, rotates the selected head slowly when raised for maintenance purposes
4	Minute counter of section	9	Time settings

5	Reset button of the time counters per section		
---	---	--	--

### 6.15 Input / Output screen

In the Input / Output screens you can do a check if buttons, joysticks, sensors etc. works properly. Push the button of a applicable function and it lights up in the screen.

<p><b>Digital input</b></p> <ul style="list-style-type: none"> <li>Spare <input type="radio"/></li> <li>Spare <input type="radio"/></li> <li>Spare <input type="radio"/></li> <li>Spare <input type="radio"/></li> <li>Spare <input type="radio"/></li> <li>Seat Switch <input checked="" type="radio"/></li> <li>EM-Stop <input checked="" type="radio"/></li> <li>Spare <input type="radio"/></li> <li>Therm. grinder Left <input type="radio"/></li> <li>Therm. grinder Middle <input type="radio"/></li> <li>Therm. grinder Right <input type="radio"/></li> <li>Therm. Dust Coll. <input type="radio"/></li> <li>Spare <input type="radio"/></li> <li>Therm. Compressor <input type="radio"/></li> </ul>	<p><b>Digital input</b></p> <ul style="list-style-type: none"> <li>Lights On/Off <input checked="" type="radio"/></li> <li>Activate System <input checked="" type="radio"/></li> <li>Release Remote <input type="radio"/></li> <li>Dust Collector On/Off <input type="radio"/></li> <li>Compressor On/Off <input type="radio"/></li> <li>Freeflow On/Off <input type="radio"/></li> <li>Grinders On <input type="radio"/></li> <li>Grinders Off <input type="radio"/></li> <li>Horn <input type="radio"/></li> <li>Rotate 360 <input type="radio"/></li> <li>Cruise Speed <input checked="" type="radio"/></li> <li>Spare <input type="radio"/></li> <li>Main Supply <input checked="" type="radio"/></li> <li>Maintenance Supply <input type="radio"/></li> <li>Spare <input type="radio"/></li> <li>Spare <input type="radio"/></li> </ul>	<p><b>Digital output</b></p> <ul style="list-style-type: none"> <li>Grinder Left Up <input type="radio"/></li> <li>Grinder Left Down <input type="radio"/></li> <li>Grinder Middle Up <input type="radio"/></li> <li>Grinder Middle Down <input checked="" type="radio"/></li> <li>Grinder Right Up <input type="radio"/></li> <li>Grinder Right Down <input checked="" type="radio"/></li> <li>Pneumatic On/Off <input checked="" type="radio"/></li> <li>Freeflow Left <input type="radio"/></li> <li>Freeflow Middle <input type="radio"/></li> <li>Freeflow Right <input type="radio"/></li> </ul>	<p><b>Digital output</b></p> <ul style="list-style-type: none"> <li>Release Controls <input type="radio"/></li> <li>Dust Collector On <input checked="" type="radio"/></li> <li>Compressor On <input checked="" type="radio"/></li> <li>Freeflow On <input checked="" type="radio"/></li> <li>Lights On <input checked="" type="radio"/></li> <li>Grinders On <input checked="" type="radio"/></li> <li>Remote not active <input checked="" type="radio"/></li> <li>Lights On/Off <input checked="" type="radio"/></li> <li>Left Wheel On <input checked="" type="radio"/></li> <li>Right Wheel On <input checked="" type="radio"/></li> <li>Compressor <input checked="" type="radio"/></li> <li>Water Pump On <input type="radio"/></li> <li>Backing up Alarm <input type="radio"/></li> <li>Puls Valve 1 <input type="radio"/></li> <li>Puls Valve 2 <input type="radio"/></li> <li>Buzzer <input type="radio"/></li> </ul>	<p><b>Digital output</b></p> <ul style="list-style-type: none"> <li>Brake Left Wheel <input checked="" type="radio"/></li> <li>Brake Right Wheel <input checked="" type="radio"/></li> <li>Battery Supply Act. <input checked="" type="radio"/></li> <li>Spare <input type="radio"/></li> <li>Spare <input type="radio"/></li> <li>Spare <input type="radio"/></li> <li>Spare <input type="radio"/></li> <li>Spare <input type="radio"/></li> <li>BlastSense Power on <input checked="" type="radio"/></li> <li>BlastSense Working <input checked="" type="radio"/></li> <li>BlastSense Error <input type="radio"/></li> <li>Spare <input type="radio"/></li> <li>Spare <input type="radio"/></li> <li>Spare <input type="radio"/></li> <li>Spare <input type="radio"/></li> <li>Spare <input type="radio"/></li> </ul>
<p><b>Analog output</b></p> <ul style="list-style-type: none"> <li>Proportional Valve 18400</li> <li>Spare 0</li> </ul>	<p><b>Analog Input</b></p> <ul style="list-style-type: none"> <li>Joystick FWD/REV 2542</li> <li>Grinder Left U/D 2521</li> <li>Grinder Middle U/D 2529</li> <li>Grinder Right U/D 2512</li> <li>Joystick Left/Right 11896</li> <li>Drive Speed 9562</li> <li>Grinder Speed 5233</li> <li>Spare 4000</li> </ul>	<p><b>Analog Input</b></p> <ul style="list-style-type: none"> <li>Grinder Head Press. 4087</li> <li>Main Pressure 4126</li> <li>Vacuum 4000</li> <li>Battery Voltage 20000</li> <li>Left Cylinder Pos. 14250</li> <li>Middle Cylinder Pos. 18523</li> <li>Right Cylinder Pos. 18591</li> <li>Spare 4000</li> </ul>	<div style="background-color: #cccccc; padding: 5px; display: inline-block;">Settings</div>	

### 6.16 Remote Input / Output screen



<b>Digital input</b> Dust Collector <input type="radio"/> Compressor <input type="radio"/> Spare <input type="radio"/> Spare <input type="radio"/> Grinder On <input type="radio"/> Grinder Off <input type="radio"/> Grinders Up <input type="radio"/> Grinders Down <input type="radio"/> <b>Digital input</b> Page 1 <input type="radio"/> Page 2 <input type="radio"/> Page 3 <input type="radio"/> Page 4 <input type="radio"/> Spare <input type="radio"/> Spare <input type="radio"/> Spare <input type="radio"/> Spare <input type="radio"/> <b>Analog output</b> Screen Line 1    0 Screen Line 2    0 Screen Line 3    0 Screen Line 4    0	<b>Digital input</b> Grinder Speed 1 <input type="radio"/> Grinder Speed 2 <input type="radio"/> Grinder Speed 4 <input type="radio"/> Grinder Speed 8 <input type="radio"/> Rotate 360 <input type="radio"/> Freeflow <input type="radio"/> Cruise Control <input type="radio"/> Spare <input type="radio"/> <b>Digital input</b> Remote On <input type="radio"/> Remote Hold <input type="radio"/> Start / Horn <input type="radio"/> Spare <input type="radio"/> Spare <input type="radio"/> Spare <input type="radio"/> Watchdog <input checked="" type="radio"/> Tilt Sensor <input type="radio"/> <b>Analog Input</b> Drive Left/Right    0 Drive FWD/REV    0 Drive Speed    0	<b>Digital input</b> Drive Left <input type="radio"/> Drive Right <input type="radio"/> Spare <input type="radio"/> Spare <input type="radio"/> Drive FWD <input type="radio"/> Drive REV <input type="radio"/> Spare <input type="radio"/> Spare <input type="radio"/> <b>Digital output</b> Led 1 <input type="radio"/> Led 2 <input type="radio"/> Buzzer 1 <input type="radio"/> Buzzer 2 <input type="radio"/> Vibrator <input type="radio"/> Red Screen <input type="radio"/> Spare <input type="radio"/> Pairing <input type="radio"/>	<b>Digital output</b> Dust Collector <input type="radio"/> Compressor <input type="radio"/> Start Grinder <input type="radio"/> Stop Grinder <input type="radio"/> Freeflow <input type="radio"/> Dust Collector High <input type="radio"/> Dust Collector Medium <input type="radio"/> Dust Collector Low <input type="radio"/>	<b>Digital output</b> Imperial Units <input type="radio"/> Metric Units <input checked="" type="radio"/> Cruise Control <input type="radio"/> Spare <input type="radio"/> Spare <input type="radio"/> Spare <input type="radio"/> Spare <input type="radio"/>
---	--	--	--	--

Settings

## 7. Troubleshooting

Failure	Possible cause	Action
Excessive vibration or/and unusual noises	<p>Imbalance due to worn or broken grinding tools.</p> <p>Worn out buffers or buffer rubbers.</p> <p>The bearing is damaged.</p>	<p>Replace all worn or broken parts.</p> <p>Replace all worn or broken parts.</p> <p>Do a check of the bearings on the axle of the wheel shaft and the axle of the drive-motor shaft. Replace if necessary.</p>
Reduced or no grinding performance	<p>Grinding tools reach the maximum permissible wear.</p> <p>Inappropriate grinding tool for the application.</p>	<p>Replace the worn parts.</p> <p>Replace the grinding tools with recommended grinding tools for the surface.</p>
Motor does not start	<p>Missed phase.</p> <p>Component is damaged.</p>	<p>Disconnect the mains power supply, wait for 5 minutes and set the switch to on again.</p> <p>Do a check of the mains power supply and try set the switch to on again. Find fault and replace damaged component.</p>
Motor protection triggers while running	<p>Motor protections switch triggered because of overload.</p> <p>Motor is damaged.</p>	<p>Reduce additional load.</p> <p>Do a check of the motor.</p>

Grind motor does not start	<p>Error in start-up.</p> <p>Too much head pressure, maximum amps on grind motor.</p>	<p>Do a check of the colour of the ON/OFF switches on the touch screen (5. Operating, item 43, 44 and 45).</p> <p>Reduce the head pressure to: 0, +10% or +20% (Refer to chapter 5. Operating, item 40 and 41).</p>
Drive system does not work or grinding heads do not work		Remove the power supply (reset the system) and connect power supply again.

Failure	Cause	Check	Action
Product does not start	<p>No power supply.</p> <p>Incorrect voltage.</p> <p>Battery voltage too low.</p>	<p>Do a check if the supply cable is connected in the wall socket/generator.</p> <p>Do a check of the main switch (when applicable).</p> <p>Do a check of supply voltage.</p> <p>Do a check of voltage relays (when applicable).</p> <p>Battery voltage, must be at least 47 V.</p>	<p>Connect the cable. Set the main switch to on (when applicable). Do a check of voltage relays switch (when applicable).</p> <p>Let an electrician do a check if there is sufficient voltage on terminals. Do a check if battery loader is loading the batteries.</p>
Supply is OK but no control voltage	<p>EM-stop activated.</p> <p>No control Voltage.</p>	<p>Do a check if the EM-stop is pushed in.</p> <p>Do a check of the circuit breakers.</p>	<p>Turn the knob to stop.</p> <p>Reset circuit breakers when they are off.</p>
Grinder motor does not start when the start button is pushed on HMI or when start switch is on (when applicable depending type)	<p>Drive not RDY or in Fault</p>	<p>Error message in frequency drive (also refer to drive manual).</p>	<p>Do a check of the fault message and follow the steps from a drive manual. If it is "STO" or "PWR" (it depends on type) it means there is no 24 Vdc to these inputs. Do a check of EMstop circuit (refer to above).</p>

## 8. Technical data

	<p>BMG 2200RC 3x 400 V</p>
--	--------------------------------

Power consumption	62 kW max.
Electrical consumption	3x 400 V
Frequency	50 Hz
Amperage connection	5 pole / 125 Amp
Amperage consumption	124 Amp
Length	3400 mm / 11.15 ft
Width	2208 mm / 7.24 ft
Height	1975 mm / 6.48 ft
Weight machine	3035 kg / 6691 lbs
Weight grinding head	320 kg
Diamond discs / pads	9x Ø240 mm
Work width	2150 mm / 85 in. / 7.5 ft
Rotation speed discs	400 – 1200 min <sup>-1</sup>
Allowed working ambient temperature	-5 – +20 °C
Maximum gradeability	8%
Sound pressure <sup>1</sup>	84 dB(A)

The electrical diagrams of the electrical system are placed inside of the control panel.  
Design and specifications are subject to change without notice by Husqvarna BV.

If the grinding machine has power from a generator, the generator must be operated in accordance with the current EN-VDE directives (this applies to the protective ground conductor in particular) in order to make sure that all safety devices operate correctly and to eliminate possible damage to electrical components.

---

<sup>1</sup> Sound pressure level LP according to EN ISO 11202:2010. Uncertainty KPA 2.5 dB(A).

## Dimensions

---

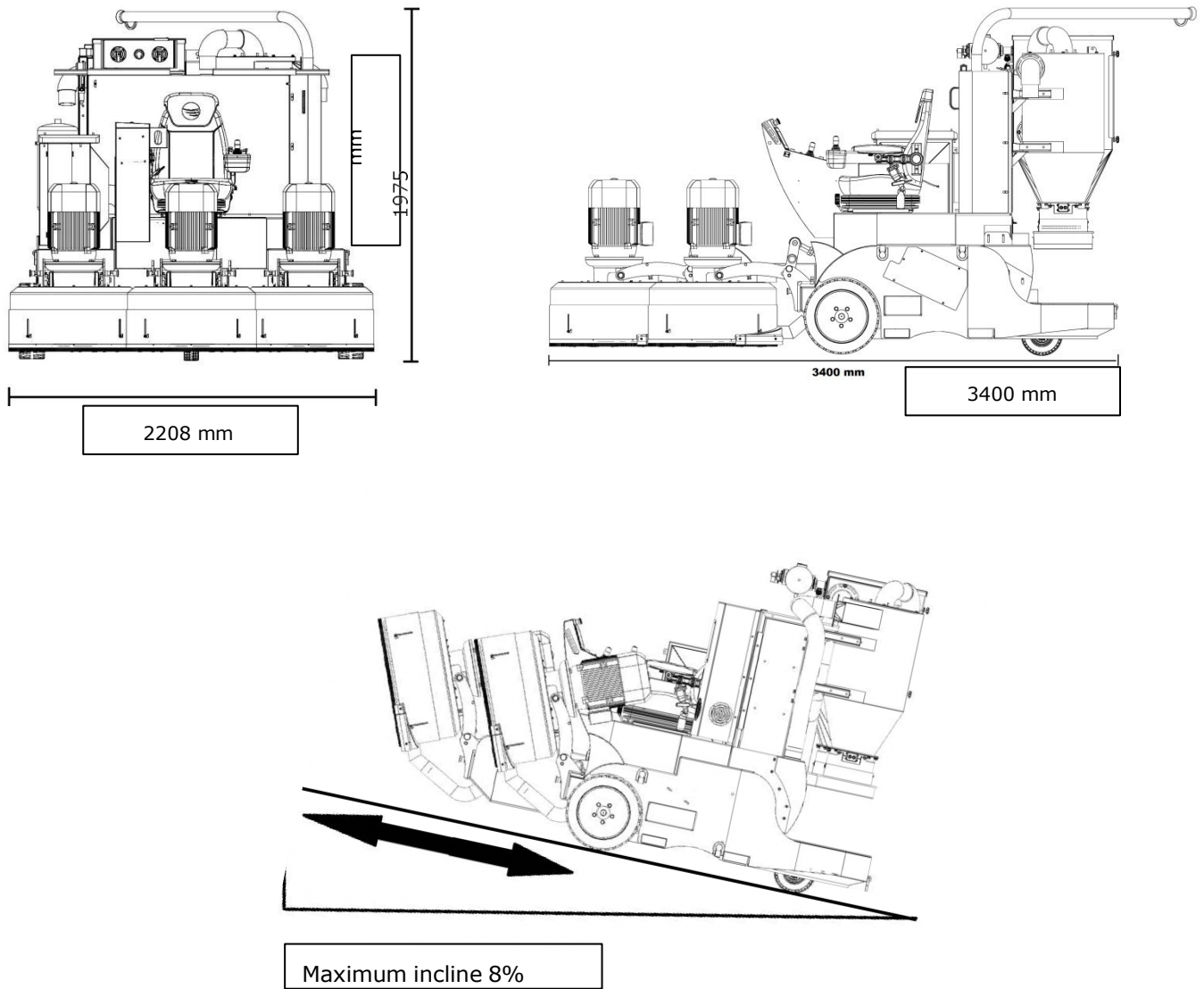

Old equipment contains valuable materials which are valuable for re-processing. These materials form an environmental and health hazard. It is not permitted to dispose this product as normal household waste. Obey the local recycling requirements and applicable regulations.

Despite the fact that this guide is made with care, Husqvarna takes no liability for errors in the manual and the possible consequences. We are naturally very interested in your findings and additions. No part of this publication may be reproduced and/or published in print, photocopy, or other form without prior permission by Husqvarna.



## EU Declaration of Conformity

HCP-BMG2200C-H-24-3E

We, Husqvarna AB, SE 561 82 Huskvarna, SWEDEN, Tel. +46 36 146500 declare on our sole responsibility that the product:

Description	Floor grinder
Brand	HUSQVARNA
Type / Model	BMG 2200 RC
Identification	Serial numbers dating from 2025 and onwards

complies fully with the following EU directives and regulations:

Directive/Regulation	Description
2006/42/EC	"relating to machinery"
2014/53/EU	"relating to radio equipment"
2011/65/EU	"relating to restriction of hazardous substances"

and that the following standards and/or technical specifications are applied;

EN ISO 12100:2010

EN 55011:2016+A1:2017+A11:2020+A2:2021

EN 61000-6-2:2019

ETSI EN 300 328 V2.2.2

Partille, 2025-02-21

Christian Nyberg

Senior Director, R&D Heavy Equipment  
Husqvarna AB, Construction Division

Responsible for technical documentation

UK Importer:

Husqvarna UK Ltd

Preston Road, Co. Durham

DL5 6UP



[www.husqvarnaconstruction.com](http://www.husqvarnaconstruction.com)

Original instructions



1143615-26 Rev. B

2023-07-21